

# REFERENCE GUIDE

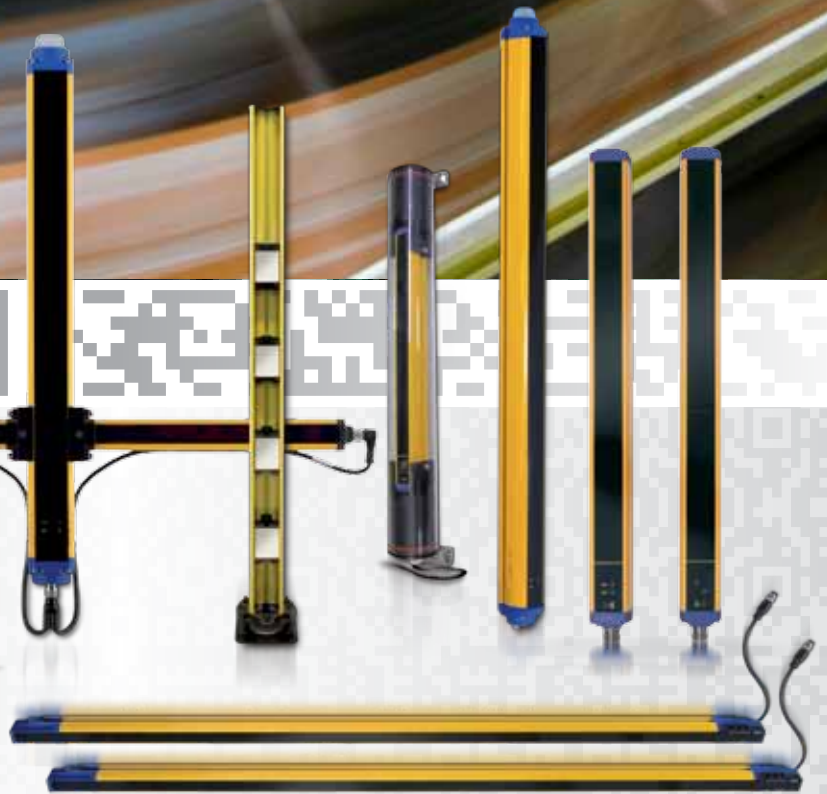

> Safety



Information in this publication is provided to guide customers in the choice of products in DATALOGIC portfolio. It has to be considered indicative and concise. For the correct use of safety components described, please always refer to additional information you can find on products datasheets and manuals, as well as to the legislation in force at the moment and in the country of their use.

You can find more detailed informations (manuals and datasheets) about products described in this reference guide on the DATALOGIC website ([www.datalogic.com](http://www.datalogic.com)).

# DATALOGIC: SOLUTIONS FOR INDUSTRIAL AUTOMATION

Datalogic Industrial Automation is an industry-leader in products and solutions for material handling, traceability, inspection and detection applications.

With the acquisitions of Accu-Sort and PPT Vision in 2012, the company offers a comprehensive portfolio of products, technologies and solutions delivered by a team of skilled professionals dedicated in providing superior service to customers.

Datalogic is the partner of choice for organizations in the Industrial Automation market.

## Factory Automation

- AUTOMOTIVE
- ELECTRONICS
- FOOD & BEVERAGE
- GENERAL MANUFACTURING
- HEALTHCARE - PHARMACEUTICAL

## Transportation & Logistics

- AIRPORTS
- COURIER, EXPRESS PARCEL (CEP)
- POSTAL
- RETAIL DISTRIBUTION

## Product portfolio

Datalogic Industrial Automation has the most comprehensive offering of products and solutions for traceability, inspection and detection applications in factory automation and logistics processes: industrial LASER scanners, cameras and vision systems, sensors, machine safety devices and LASER markers.

## Identification

Even the most demanding and efficient automation of identification processes can leverage Datalogic Industrial Automation's leadership in the market. We manufacture the world's most comprehensive family of fixed-mount line and omnidirectional scanners.

We also offer the latest CCD vision technology with the world's largest installed base of CCD systems for bar code reading and dimensioning.

All of our AUTO-ID products and solutions leverage the broadest decoding library that has been developed through the years. Datalogic's comprehensive AUTO-ID portfolio is used in a wide range of applications and machines which are behind many of the everyday processes that keeps the global economy running.

## Sensors & Safety

Datalogic Industrial Automation offers a best-in-class, comprehensive product portfolio of photoelectric and proximity sensors, rotary encoders, temperature controllers and measurement devices, as well as type 2 and type 4 safety light curtains.

These product lines provide solutions for applications involving color, contrast and luminescence, label detection, dimensional and distance measurement, in addition to machine safeguarding and access control in dangerous areas.

## Machine Vision

The Datalogic Industrial Automation machine vision product line encompasses both hardware and software while covering a wide range of performance and price point requirements. The vision portfolio of products and solutions ranges from simple vision sensors to smart cameras and embedded vision systems.

## Laser Marking

Laser Marking sources and systems provide value driven marking solutions for automotive, metal tools, medical, electronics and packaging. Datalogic Industrial Automation offers an extensive range of state-of-the-art technology, excellent performance and high reliability marking equipment.





# SAFETY

**Datalogic** has more than 40 years of experience in the sensors and safety sector, developing their first product, a **Photoelectric Sensor**, in 1972. Today, Datalogic is one of the largest manufacturers of sensor and safety products worldwide.

**Datalogic** is the market leader in Italy for photoelectric sensors and safety light curtains, ranking among the **top-10 manufacturers** in Europe by market share\*

Datalogic's **Sensors and Safety** portfolio solves customer applications in **Factory Automation**, specializing in Processing and Packaging machinery, and Automated Material Handling Systems related to Manufacturing Industries such as Automotive, Electronics, Pharmaceutical, Food & Beverage, Paper and Printing, Woodworking, Ceramics, Glass, Textiles etc.

\* (source: based on VDC 2010 - 2011)

<b>APPLICATIONS</b>	De-Palletizing	Storage & Retrieval
	Washing	Cartoning
	Filling	Wrapping
	Capping	Vertical Form Fill & Seal
	Labeling	Processing
	Case Packing	
	Stretch-wrapping	
	Palletizing	



High performance protection tube for harsh environments

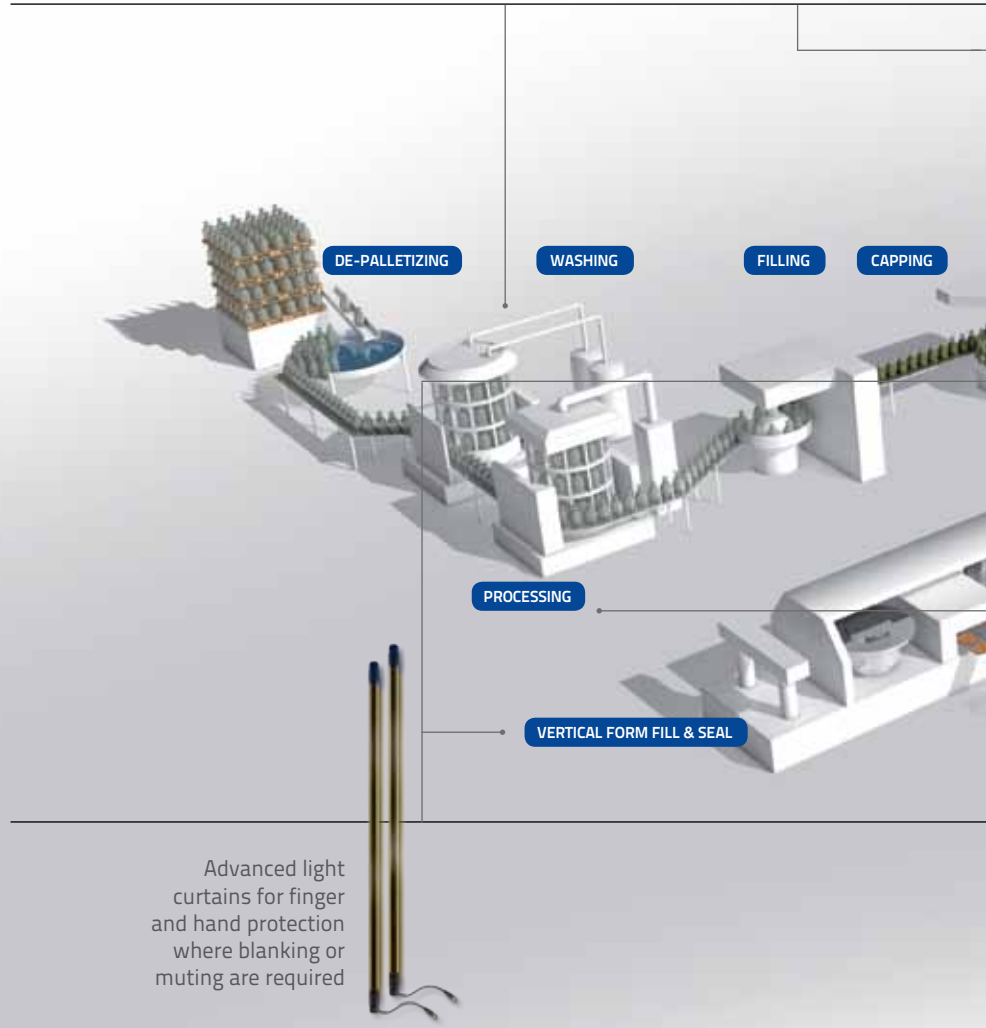





Interfaces between light curtains and safety system

Long distance light curtains, stands and mirrors for perimetral protection



Operator interfaces to control light curtains and indicate muting status

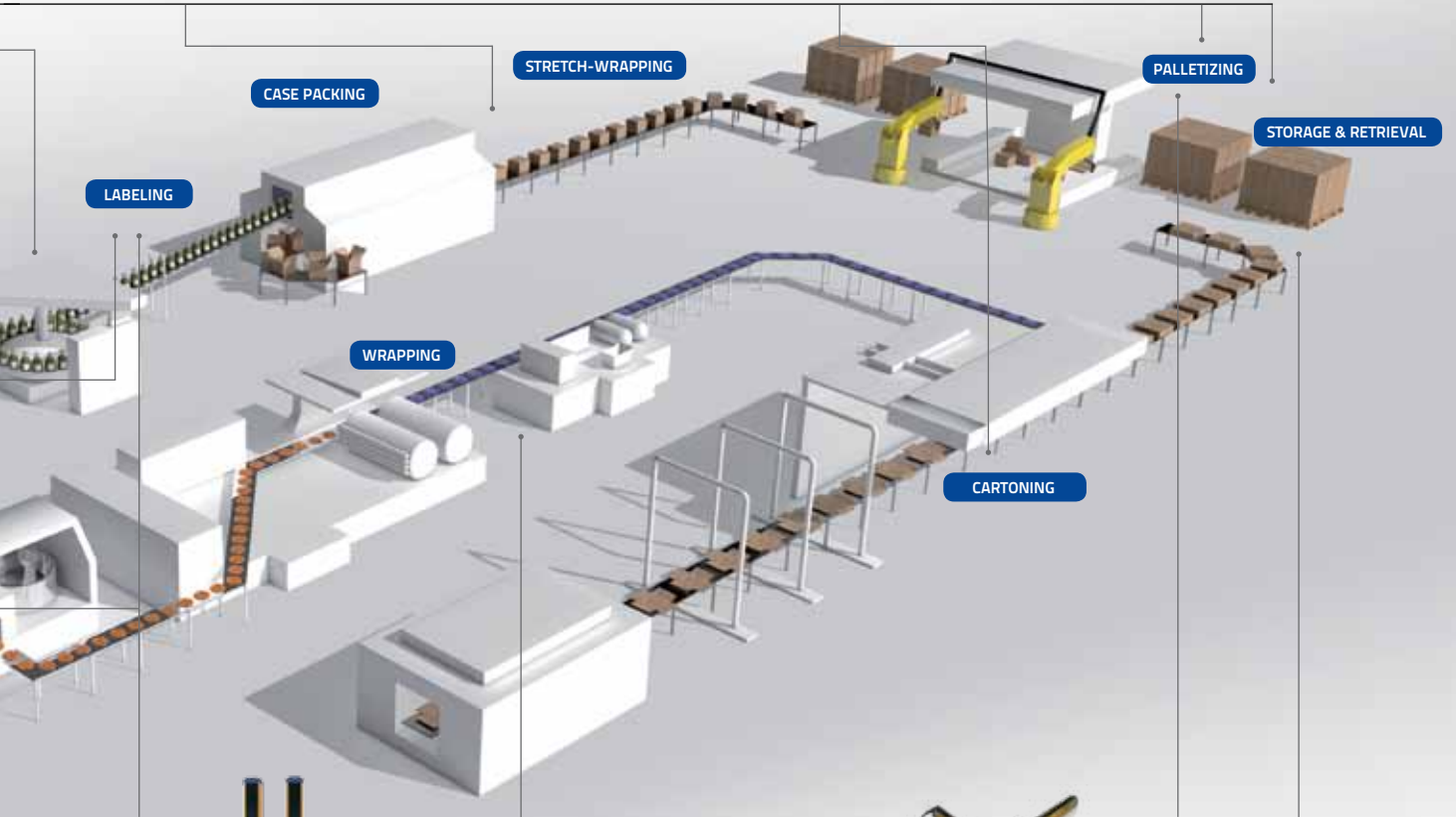

Finger or hand protection light curtain to reach close distance to the working point



Safety Light curtains for body protection with Muting function



## SAFETY PRODUCTS

### SAFETY PRODUCT RANGE

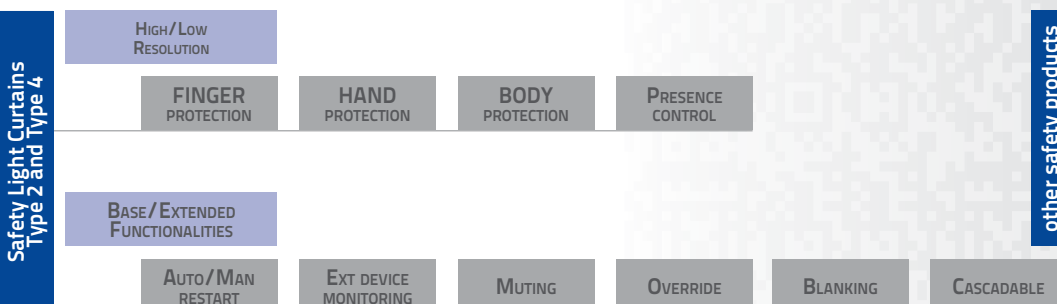



## SELECTION GUIDE

8

SELECTION GUIDE .....	10
· Performance level (pl)	
· Type	
· Detection capability (or resolution)	
· Detection zone	
· Retroreflective light curtains	
· Cascading	
· Response time	
· Manual or automatic restart	
· External device monitoring (edm)	
· Muting	
· Override	
· Blanking	
· Software configuration	
SELECTION TABLE .....	18

## SAFETY SENSORS

20

	SG2 BASE .....	22
	SG2 EXTENDED	
	SG4 BASE	
	SG BODY COMPACT BASE .....	28
	SG BODY COMPACT MUTING	
	SG BODY BIG BASE .....	36
	SG BODY BIG MUTING	
	SG BODY REFLECTOR BASE .....	42
	SG BODY REFLECTOR MUTING	
	SG2 MUTING .....	50
	SG4 EXTENDED	
	SINGLE BEAM SAFETY SENSORS .....	56
	SAFETY CONTROL UNITS	



- BRACKETS ..... 64
- Metal angled brackets
  - Plastic angled brackets
  - Cascade brackets
  - Rear brackets
  - Rotative brackets



- MIRRORS AND STANDS ..... 70
- Stands with adjustable mirrors
  - Mirrors
  - Single beam mirror
  - Stands
  - Mounting kits for mirrors



- ACCESSORIES FOR MUTING ..... 76
- Muting arms, brackets, cables
  - Muting lamps



- SAFETY UNITS AND INTERFACES ..... 82
- Connection boxes



- OTHER ACCESSORIES ..... 86
- Protection tubes
  - Lens shields
  - Laser pointer
  - Communication interface
  - Test pieces

- SAFETY STANDARDS REFERENCE LIST ..... 92
- DEFINITIONS ..... 93
- SAFETY DISTANCE CALCULATION ..... 94





# SELECTION GUIDE



# SELECTION GUIDE



# SELECTION GUIDE

## SELECTION GUIDE

The selection of safety sensors for use in machinery is part of the overall risk reduction process, which starts with the analysis and evaluation of all possible risks the machine presents and ends with the validation and testing of the safety system. The sensors chosen should fulfill any safety requirements specific to the machine they will be mounted on. If there are no machine-specific requirements, the safety system should be designed to comply with all general safety and health standards. The overall system design dictates the parameters the safety sensors must meet. The following list of parameters and functions related to safety sensors can serve as a checklist to help in the selection process.

NUMBER	DEFINITION	VALUES				
		a	b	c	d	e
1	Performance level required	a	b	c	d	e
2	Type	2			4	
3	DETECTION CAPABILITY					
	Finger protection	14 mm				
	Hand protection		30 mm			
	Arm protection/Presence			50 mm	90 mm	
	Body protection	2 beams 500 mm	3 beams 800 mm	4 beams 900 mm	4 beams 1200 mm	
4	DETECTION ZONE					
	Height	from 150 mm to 1800 mm				
	Operating range	from 0.2 m to 60 m				
	Zero dead zone	yes			no	
5	Retroreflective light curtains	yes			no	
6	Cascading	yes			no	
7	Response time	from 8 ms to 33 ms				
8	Manual or automatic restart	Manual			Automatic	
9	External Device Monitoring (EDM)	yes			no	
10	MUTING					
	Type of muting	T			L	
	Integrated muting lamp	yes			no	
	Partial muting	yes			no	
11	Override	yes			no	
12	BLANKING					
	Fixed Blanking	yes			no	
	Floating Blanking	yes			no	
	Reduced resolution	yes			no	
13	Software configuration	yes			no	



# SELECTION GUIDE

## 1. Performance Level (PL) and required Performance Level (PLr)

Performance level is one of five discrete levels (a, b, c, d, e) that specify the ability of the safety-related part of a control system to perform a specific safety function. The performance level depends on the system design, the reliability of components used, the diagnostic coverage of dangerous faults, and on the ability of the safety parts to avoid common cause and systematic faults.

The minimum required Performance Level (PLr) to reduce a risk is determined by following the diagram in fig. 1, which takes into account three factors: the severity of injury, the frequency of exposure to hazard, and the possibility to avoid the hazard. Performance level and its calculation methods are described in EN ISO 13849-1.

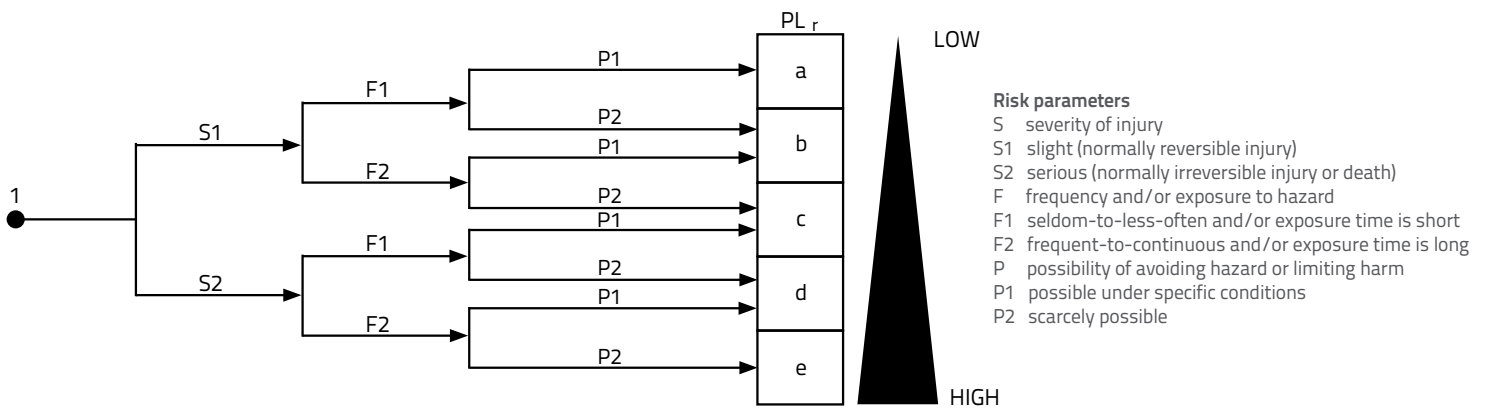

Fig. 1 Required Performance Level

## 2. Type

Safety sensors whose function is to detect the interruption of beams by an object are called Active Optoelectronic Protective Devices (AOPD). AOPDs are classified in two Types (Type 2 and Type 4) depending on their design and optical performance.

The optical performance is dependent on the maximum limit of the effective aperture angle (EAA), that is  $-/+5^\circ$  for Type 2, and  $-/+2.5^\circ$  for Type 4. A lower EAA results in a more focused beam.

Type and Performance Level are directly correlated: Type 2 Sensors must reach at least PL c, and Type 4 Sensors must reach at least PL e.

Conversely, the maximum PL that can be reached for a safety function that includes the use of a Type 2 AOPD is PL c, while for a Type 4 AOPD, the maximum is PL e.

Based on these considerations, to reduce the highest risks on machines, Type 4 AOPDs should be used (see Fig. 2).

Active optoelectronic protective devices and corresponding Types are described in IEC 61496-1 and IEC 61496-2.

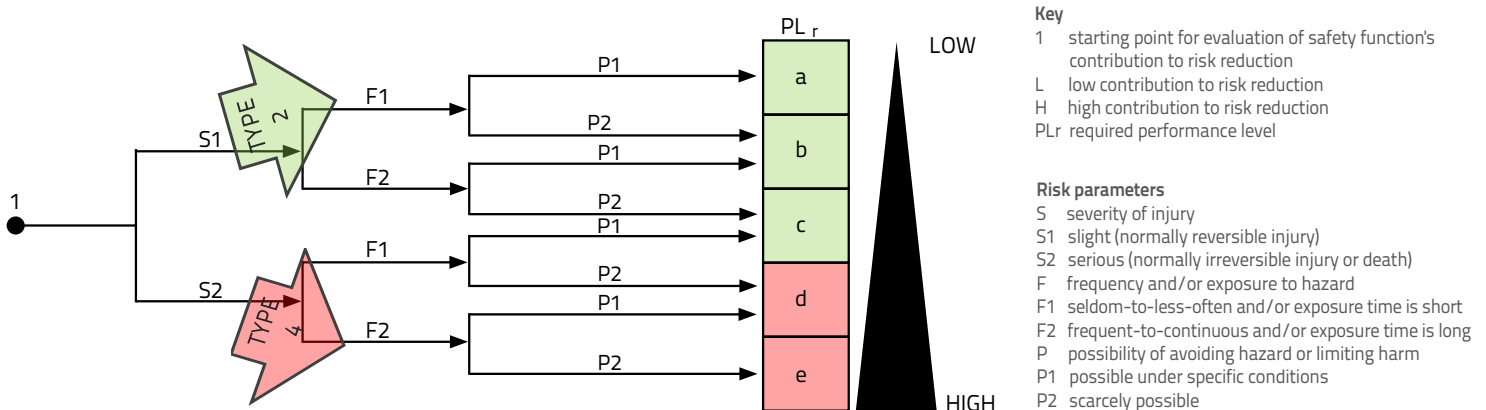

Fig. 2 AOPD Type and Performance Level

# SELECTION GUIDE

## 3. Detection Capability (or Resolution)

The detection capability of a light curtain is the diameter of the smaller object that will activate the device when it's placed in any point of the detection zone.

The value of the detection capability, together with response time, is crucial to calculating the minimum safety distance required between the light curtain and the dangerous zone.

For single light beam sensors and for multiple light beams sensors (2, 3 or 4 beams), in place of detection capability, it's common to use the number of light beams. In this case, their purpose is to provide 'body protection', detecting the passage of the entire body of a person.

For an introduction to the minimum safety distance calculation rules (described in EN 13855) see page 94 and the light curtain's technical documentation.

## 4. Detection zone

The detection zone is the area where any object whose dimensions are at least equal to the detection capability activates the light curtain.

It is defined by its **height** and by the distance between the emitter and the receiver element ("**operating range**").

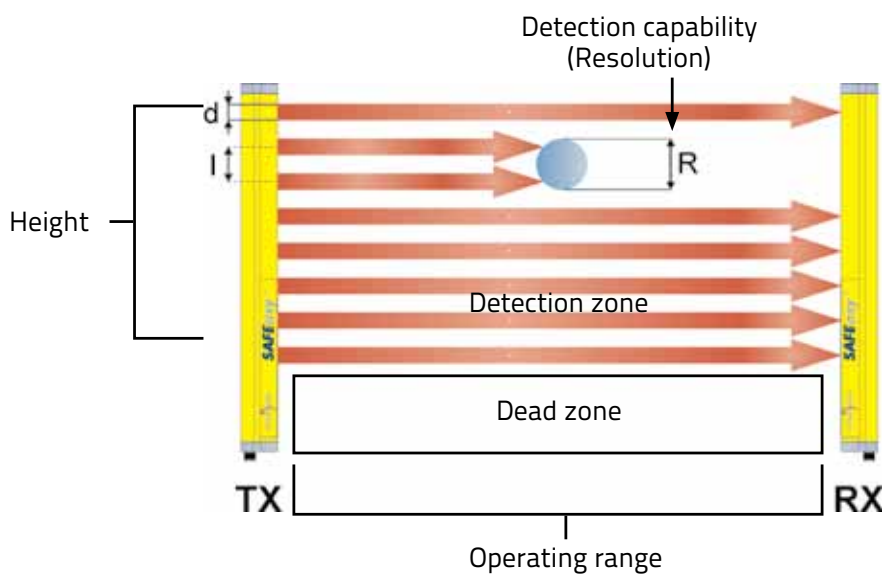

Fig. 3 Detection Zone

If the light curtain is retroreflective, the operating range is the distance between the active and the passive element. Light curtains can have a 'dead zone', in which they are not able to detect the object due to the absence of beams. When it is required that the dimension of the light curtain corresponds exactly to the height of its detection zone, the light curtain is said to have **zero dead zone**.

# SELECTION GUIDE

## 5. Retroreflective light curtains

2, 3 and 4 beams light curtains can be manufactured with all emitters and receivers on one side, and passive elements (mirrors) on the other side. The advantage of using a retroreflective light curtain is that only one side needs to be powered on.

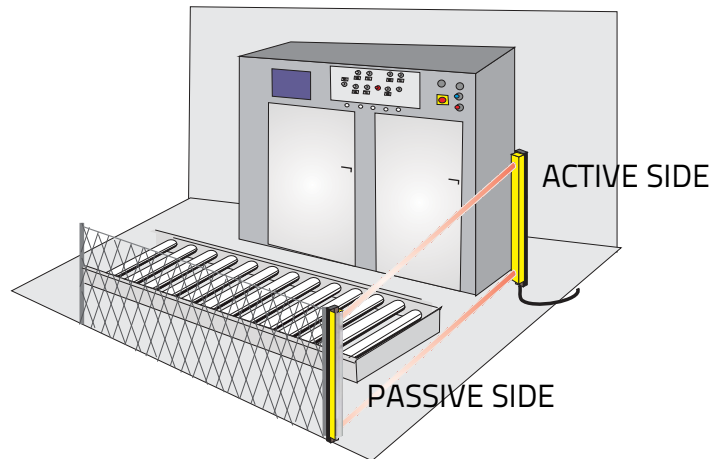

Fig. 4 Retroreflective Light Curtain

## 6. Cascading

Cascading is when two or more light curtains are connected to each other, resulting in one system that functions as a single light curtain.

Advantages of cascading are: better monitoring of dangerous areas with presence detection beyond the vertical detection zone and space and cost savings by using a single safety unit.

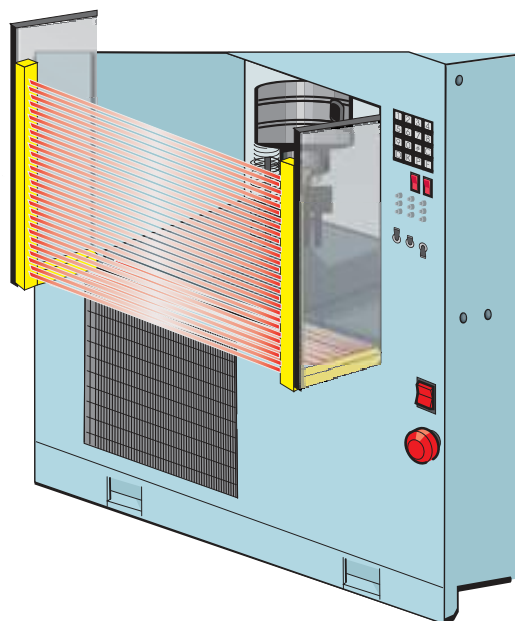

Fig. 5 Cascading



# SELECTION GUIDE

## 7. Response time

The response time is the maximum time occurring between the detection of the test object in the detection zone and the activation of the light curtain's outputs.

It is a safety relevant parameter, and its value must be taken in account when calculating the position in which the safety sensor will be placed in relation to the dangerous area.

## 8. Manual or automatic restart

Depending on the initial risk analysis of the machine, a start or restart interlock can be a safety requirement of the control system. It prevents an automatic restart of the machine during a dangerous part of the operating cycle after activation of the sensing device, or when the electrical supply of the sensor is switched on or restored after interruption. This interlock can be implemented by a manual restart of the safety controller or by the light curtain itself.

## 9. External Device Monitoring (EDM)

EDM is a function that allows the electro-sensitive protective equipment (ESPE) to monitor the state of control devices (i.e. contactors, actuators) that are driven by its outputs.

This function can be achieved by the safety controller or directly by the light curtain.

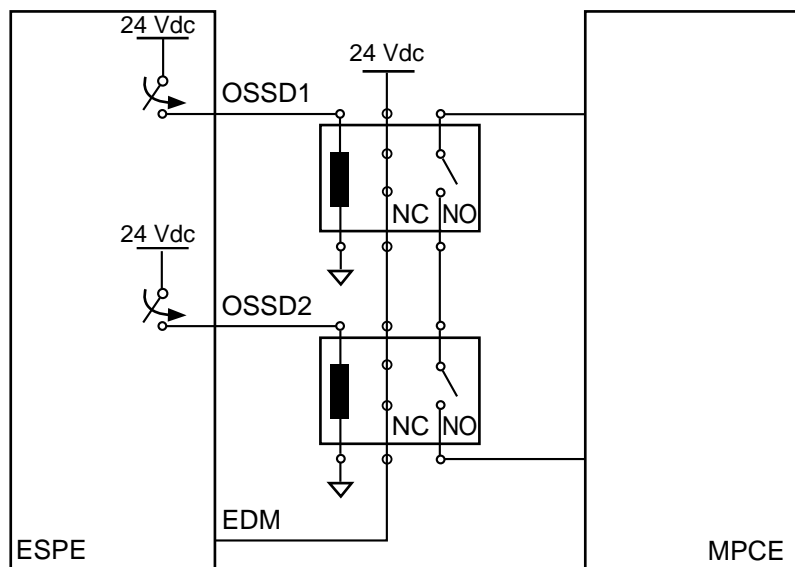

Fig. 6 External Device Monitoring wiring diagram

# SELECTION GUIDE

## 10. Muting

Muting is the temporary automatic suspension of a safety function. When a light curtain is muted, its outputs will remain ON even if an object is detected in the detection zone.

Because muting suspends a safety function, it must be implemented with all necessary precautions and in compliance with the machine-specific safety requirements.

T muting is a specific kind of muting that can be used to allow the passage of material through an opening in direction of the dangerous area or in both directions. L muting can be used only if material exits the dangerous area.

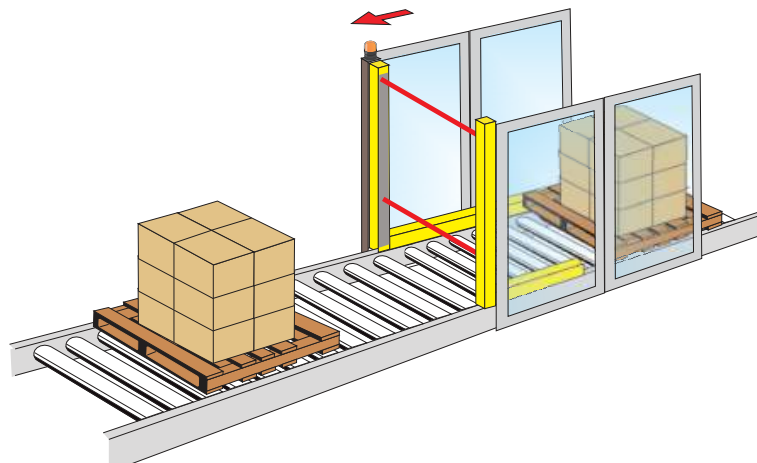

Fig. 7 Safety Light Curtain with Integrated L muting actuator

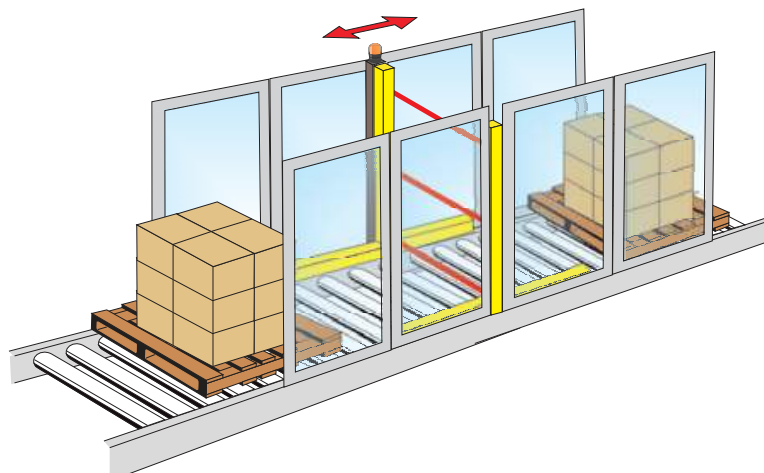

Fig. 8 Safety Light Curtain with Integrated T muting actuator

Light curtains can be provided with muting arms, with pre-wired sensors detecting the passage of material, or can be used with external muting sensors.

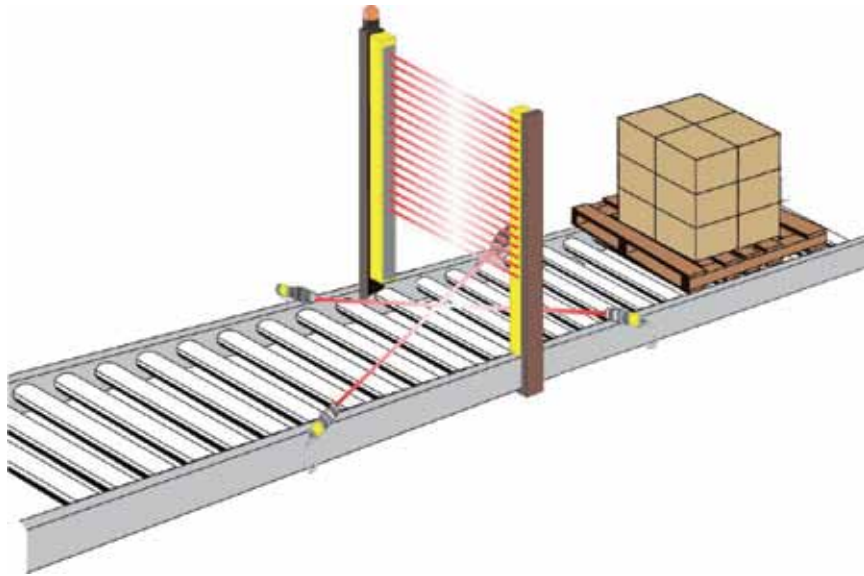

Fig. 9 Safety light curtain with external crossed beams muting sensors

Muting lamps integrated in the light curtains, or installed external to them, are designed to flash as long as the muting is active.

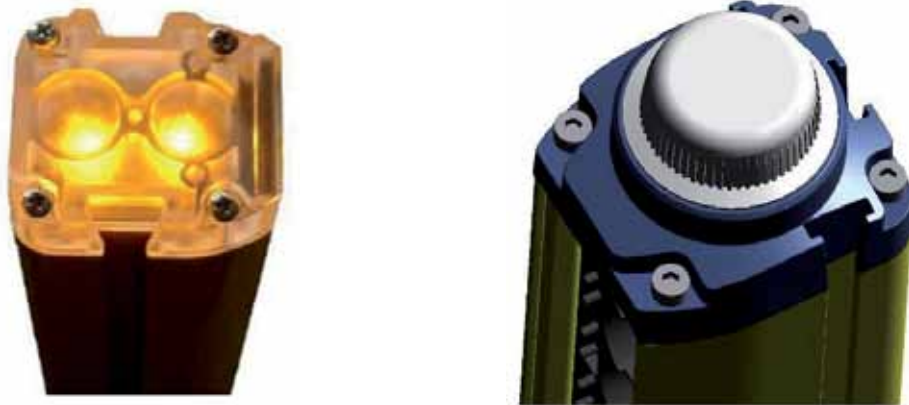

Fig. 10 Integrated muting lamps

To maintain the safety of the application, light curtains can be configured to perform the muting function only on the number of beams needed for the passage of the material (**Partial Muting**), keeping the others active.

## 11. Override

Override function is a mute dependent bypass of the light curtain, that can be provided for some applications (for example conveyor and packaging machinery) in order to clear a blockage in the area of the machine where sensors are located. The activation of the bypass function should be possible for a limited amount of time, only when at least one muting sensor is activated, and will require the use of a device located where operator can see the point of hazard.



# SELECTION GUIDE

## 12. Blanking

The blanking function is used when an object detected in a defined part of the detection zone must not cause an OFF-state of the light curtains outputs.

Blanked beams are monitored so that the absence or a change in the size or location of the object causes the light curtain's outputs to go to the OFF-state.

Fixed blanking is when the object must remain in a fixed position, with a given tolerance.

Floating blanking is when the object can move along the detection zone.

Depending on the configuration of the light curtain, in floating blanking the object can also leave the detection zone or not.

Reduced resolution is a particular kind of floating blanking, with light curtain outputs going OFF-state only when a pre-defined number of beams adjacent are interrupted, in any position along the light curtain. When reduced resolution is active, more than one small object can interrupt the light curtain beams without its output going OFF.

Blanking can affect the detection capability of the light curtain and can result in a recalculation of the minimum safety distance.

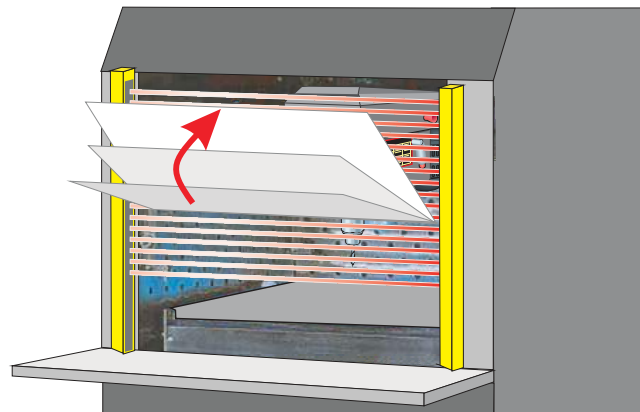

Fig. 11 Floating blanking

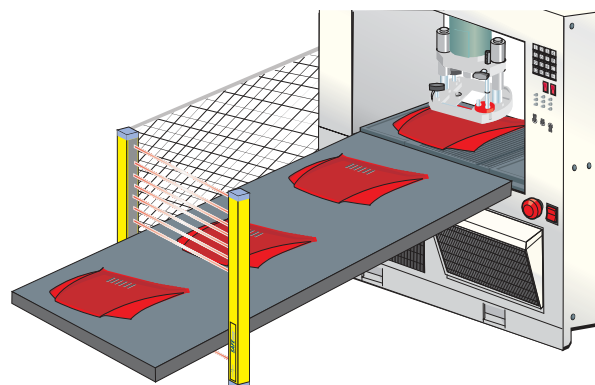

Fig. 12 Fixed blanking with tolerance

## 13. Software configuration

Setting DIP-Switch or through wiring, it is possible to set typical parameters like manual or auto reset, EDM enable or disable, muting type selection, as well as auto-teach blanking function.

A software configurator (**Graphic User Interface, GUI**) is required for more advanced functionality, such as setting the muting timeout with 1-second steps, or designing complex patterns for floating or fixed blanking.

# SELECTION TABLE

RESOLUTION	TYPE	RANGE (m)	HEIGHT (mm)
Finger (14 mm)	4	0.2 ... 6	150 ... 1800
		0.2 ... 7	300 ... 1800
Hand (30 mm)	2	0.2 ... 19	150 ... 1800
		0.2 ... 19	150 ... 1800
	0.2 ... 20	300 ... 1800	
	4	0.2 ... 19	150 ... 1800
0.2 ... 20		300 ... 1800	
Arm (40 mm)	4	6 ... 60	660/960/1260
Arm/Presence (50/90mm)	2	0.2 ... 19	150 ... 1800
		0.2 ... 19	150 ... 1800
Body (2/3/4 beams)	2/4	0.5 ... 50	500/800/900/1200
		0.5 ... 50 0.5 ... 3 <sup>A</sup> 0.5 ... 7 <sup>B</sup>	500/800/900/1200
		0.5 ... 60	500/800/900/1200
		0.5 ... 60 0.5 ... 3 <sup>A</sup> 0.5 ... 7 <sup>B</sup>	500/800/900/1200
		0.5 ... 8	500/800/900/1200
		0.5 ... 8 0.5 ... 3 <sup>A</sup>	500/800/900/1200
		0 ... 8 <sup>C</sup> 0 ... 40 <sup>C</sup>	flexible

## NOTES

- <sup>A</sup> With retroreflective muting arms
- <sup>B</sup> With emitter/receiver muting arms
- <sup>C</sup> Depending on models

# SELECTION TABLE

FUNCTIONS	ADDITIONAL HW FEATURES	FAMILY	PAGE
Manual/Auto Restart	Zero dead zone Cascade Advanced Programmable Configuration Monitoring via Ethernet/IP Error logging	SG4 EXTENDED	50
External Device Monitoring (EDM)			
Manual/Auto Restart			
External Device Monitoring (EDM)			
T, L Muting function			
Partial Muting			
Override			
Fixed blanking			
Floating Blanking			
Auto restart		SG2 BASE	22
Manual/Auto Restart		SG2 EXTENDED	22
External Device Monitoring (EDM)	Zero dead zone	SG2 MUTING	50
Manual/Auto Restart			
External Device Monitoring (EDM)			
T, L Muting function			
Partial Muting			
Override			
Manual/Auto Restart		SG4 BASE	22
External Device Monitoring (EDM)	Zero dead zone Cascade Advanced Programmable Configuration Monitoring via Ethernet/IP Error logging	SG4 EXTENDED	50
Manual/Auto Restart			
External Device Monitoring (EDM)			
T, L Muting function			
Partial Muting			
Override			
Fixed blanking			
Floating Blanking			
Manual/Auto Restart		SG4 LONG RANGE BASE	36
External Device Monitoring (EDM)		SG2 BASE	22
Auto restart		SG2 EXTENDED	
Manual/Auto Restart		SG BODY COMPACT BASE	28
External Device Monitoring (EDM)	Integrated muting lamp Integrated muting arms <sup>C</sup>	SG BODY COMPACT MUTING	28
Manual/Auto Restart			
External Device Monitoring (EDM)			
T, L Muting function		SG BODY BIG BASE	36
Override		SG BODY BIG MUTING	36
Manual/Auto Restart	Retroreflective	SG BODY REFLECTOR BASE	42
External Device Monitoring (EDM)			
Manual/Auto Restart	Retroreflective Integrated muting lamp Integrated muting arms <sup>C</sup>	SG BODY REFLECTOR MUTING	42
External Device Monitoring (EDM)			
T, L Muting function			
Override		SINGLE BEAM SENSORS	56
Manual/Auto Restart	Double muting function Low temperature Defogging Separated control unit		
External Device Monitoring (EDM)			
T, L Muting function			
Override			

# SAFETY SENSORS



# SAFETY SENSORS



# SAFETY SENSORS

## SG2 BASE SG2 EXTENDED SG4 BASE



*High reliability*  
*Easy installation and alignment*  
*Cost effective solution*

- Finger, hand, arm detection with basic functions
- 90 mm version for presence detection
- Up to 20 m operating distance
- Compact dimensions (32.3 x 36.9 mm section)
- Anti-interference coding
- IP65 Protection; IP69K with optional tube
- Unshielded cables
- Rotating and antivibration brackets



	FINGER	HAND	ARM	BODY
TYPE 2		▪	▪	
TYPE 4	▪	▪		

### SG2-14-030-00-E

TYPE	
2	Type 2
4	Type 4

MONITORED HEIGHT	
15	150 mm
30	300 mm
...	
180	1800 mm

RESOLUTION	
14	Finger: 14 mm (only Type 4)
30	Hand: 30 mm
50	Arm: 50 mm (only Type 2)
90	Arm: 90 mm (only Type 2)

VERSION	
E	Type 4, EDM, Coded
E-C	Type 2, EDM, Coded
X	Basic Function



# SAFETY SENSORS | SG2 BASE SG2 EXTENDED SG4BASE

## CHARACTERISTICS

	SG2BASE [ SG2-xx-xxx-00-X ]	SG2 EXTENDED [ SG2-xx-xxx-00-E-C ]	SG4 BASE [ SG4-xx-xxx-00-E ]
<b>GENERAL DATA</b>			
Type (EN61496-1-2)	2		4
PL (EN ISO 13849-1)	c		e
SIL (IEC 61508)	1		3
Resolution	30 - 50 - 90 mm		14 - 30 mm
Protected height	150 ...1800 mm (with 150 mm steps)		
Operating distance	0.2 ...19 m		0.2 ... 6 m (resolution 14 mm) 0.2 ...19 m (resolution 30 mm)
<b>ELECTRICAL DATA</b>			
Power supply (Vdc)	24 Vdc ± 20		
Outputs	2 PNP		
Output current	0.5 A max/each output		
Capacitive load	2.2 uF @ 24Vdc max		
Response time	8 ... 19 ms depending on model <sup>A</sup>		
Cables length (for power supply)	50 m max		
<b>MECHANICAL AND ENVIRONMENTAL DATA</b>			
Operating temperature	-10 ...+55 °C		0 ...+55 °C
Humidity	15 ... 95 % (no condensation)		
Mechanical protection	IP 65 (EN 60529)		
<b>FUNCTIONS</b>			
	Test input		
	Automatic restart	Manual/Automatic restart	
		External Device Monitoring (EDM)	
		Selectable External Device Monitoring (EDM)	
		Selectable Operating Distance	

<sup>A</sup> For detailed informations refer to related Product Datasheet or Manual

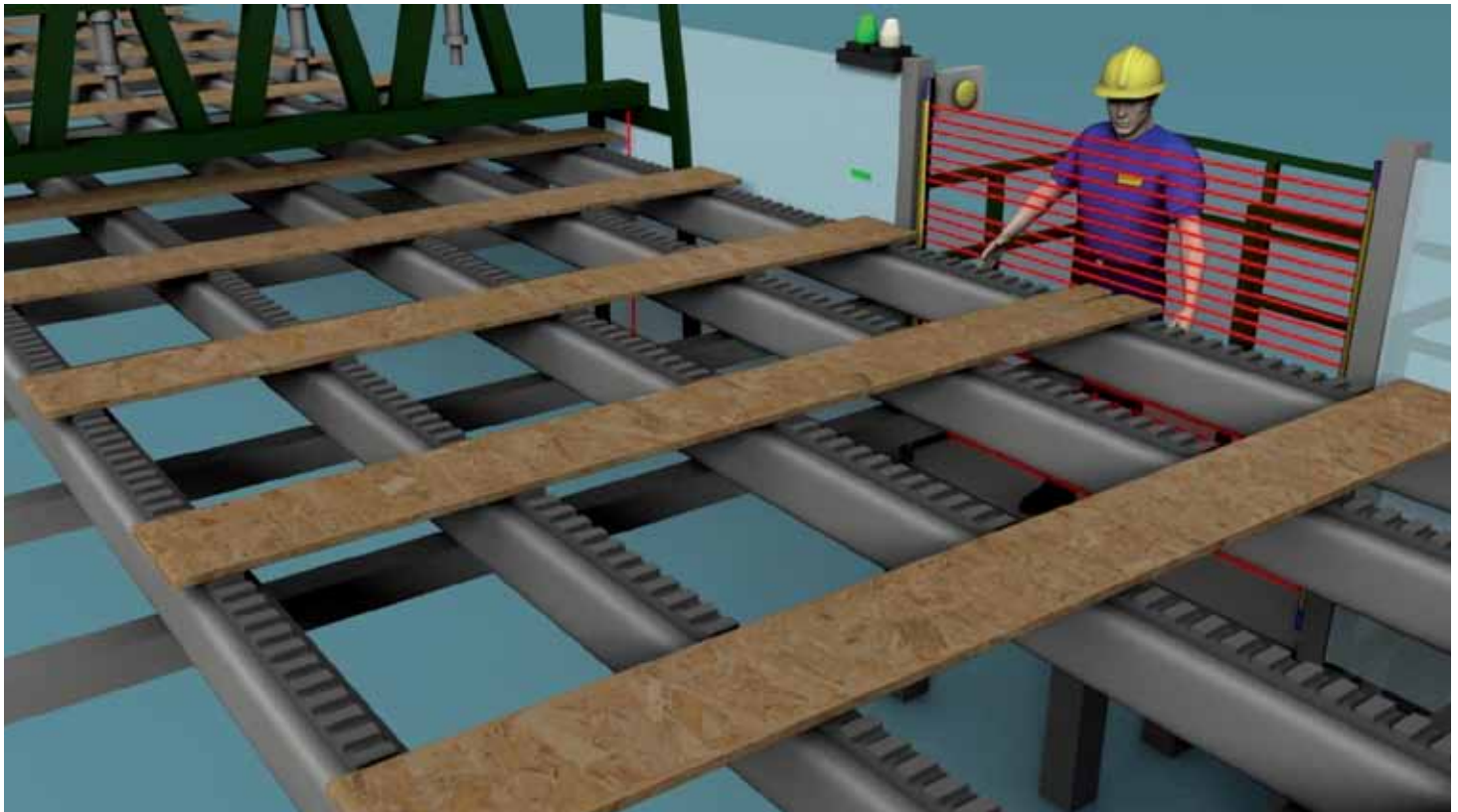

## CONNECTIONS

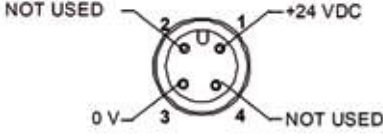
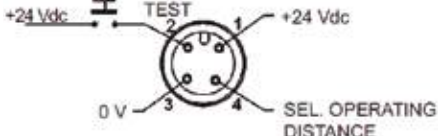
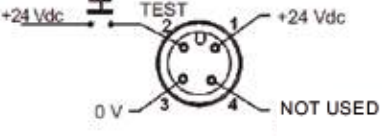
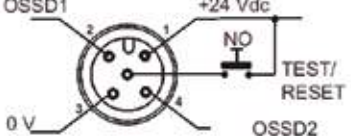
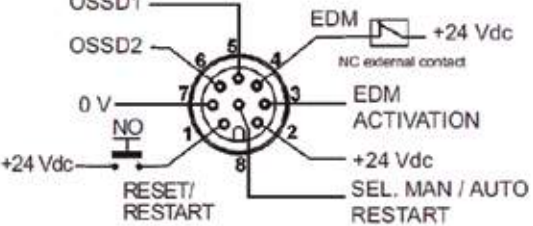
	SG2 BASE [ SG2-xx-xxx-00-X ]	SG2 EXTENDED [ SG2-xx-xxx-00-E-C ]	SG4 BASE [ SG4-xx-xxx-00-E ]
EMITTER			
RECEIVER			
NOTES			
<p>For manual restart, connect Pin 8 with Pin 6 For automatic restart, connect Pin 8 with Pin 5</p> <p>To deactivate EDM function, connect Rx Pin 3 to 24Vdc on Receiver</p>			

## ACCESSORIES

	SG2 BASE [ SG2-xx-xxx-00-X ]	SG2 EXTENDED [ SG2-xx-xxx-00-E-C ]	SG4 BASE [ SG4-xx-xxx-00-E ]
<b>BRACKETS</b>			
Standard angled brackets	ST-KSTD (included for SG2 Base and SG4 Base)		
Rotating brackets	ST-K4ROT (included for SG2 Extended)		
Antivibration support (4 pcs/6 pcs) <sup>C</sup>	ST-K4AV ST-K6AV		
Plastic brackets (4 pcs/6 pcs) <sup>C</sup>	ST-KP4MP ST-KP6MP		
<b>PROTECTION TUBES AND STANDS</b>			
IP67/IP69K Tubes	SG-IP69K series		
Protective Stands	SG-PSB series		
Stand Plate for SG-PSB	SG-P		
Protective Stands Mounting Brackets (4 pcs/6 pcs) <sup>C</sup>	ST-PS4-SG-SE ST-PS6-SG-SE		
Floor Columns	SE-S Series		
<b>MIRRORS</b>			
Deviating Mirrors	SG-DM Series		
Deviating Mirrors mounting kit for SG-PSB	ST-PS-DM		
Mirror Mounting Bracket	ST-DM		
<b>SAFETY UNITS</b>			
Safety Unit	SE-SR2		
EDM Relay Box <sup>B</sup>	---	CS ME-03VU24-Y14	
Safety control unit for single beams and SLC	SG-BWS-T4-MT		
<b>ALIGNMENT TOOL</b>			
LASER Pointer	SG-LP		
<b>NOTES</b>			

<sup>C</sup> Use 6 brackets for light curtains with length ≥ 1200 mm

<sup>B</sup> When using EDM Relay Box or Muting connection box, connect EDM input, and be sure EDM function is active on the safety light curtain

# SAFETY SENSORS | SG2 BASE SG2 EXTENDED SG4BASE

## DIMENSIONS (mm)

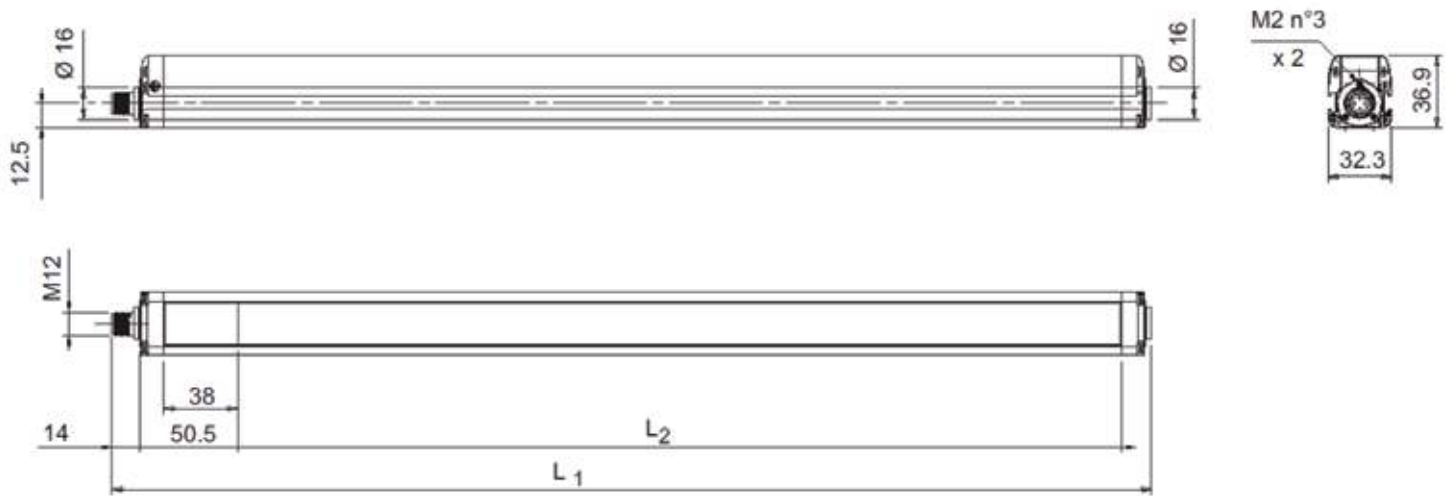

MODEL	L1 (mm)	L2 (mm)
SGx-yy-150-00-kkk	233.3	153.3
SGx-yy-030-00-kkk	383.2	303.2
SGx-yy-045-00-kkk	533.2	453.3
SGx-yy-060-00-kkk	683.2	603.2
SGx-yy-075-00-kkk	833.2	753.3
SGx-yy-090-00-kkk	983.2	903.2
SGx-yy-105-00-kkk	1133.2	1053.2
SGx-yy-120-00-kkk	1283.3	1203.3
SGx-yy-135-00-kkk	1433.2	1353.2
SGx-yy-150-00-kkk	1583.3	1503.3
SGx-yy-165-00-kkk	1733.3	1653.3
SGx-yy-180-00-kkk	1883.3	1803.3

## INDICATORS

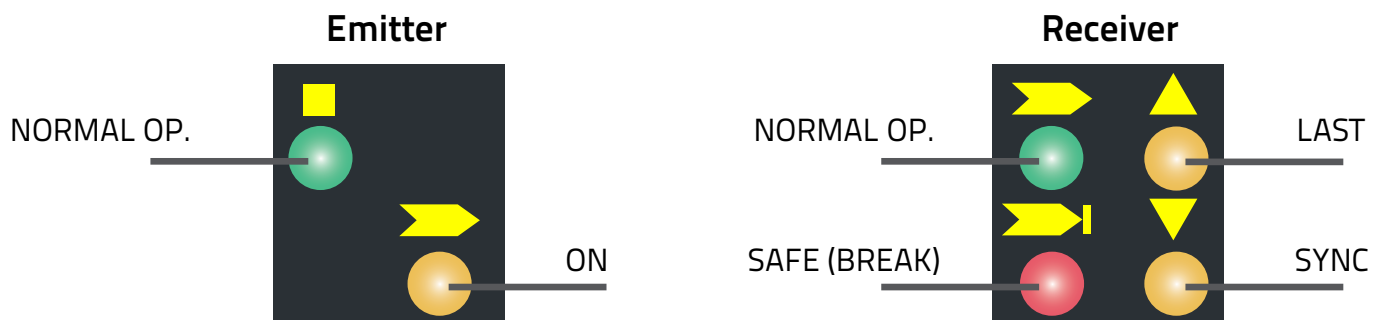

# SAFETY SENSORS

SG2 BASE  
SG2 EXTENDED  
SG4BASE

## AVAILABLE MODELS AND ORDER CODES

	SG2 BASE [ SG2-XX-XXX-00-X ]	ORDER CODE	SG2 EXTENDED [ SG2-XX-XXX-00-E-C ]	ORDER CODE	SG4 BASE [ SG4-XX-XXX-00-E ]	ORDER CODE
FINGER PROTECTION	---	---	---	---	SG4-14-015-00-E	957901000
	---	---	---	---	SG4-14-030-00-E	957901010
	---	---	---	---	SG4-14-045-00-E	957901020
	---	---	---	---	SG4-14-060-00-E	957901030
	---	---	---	---	SG4-14-075-00-E	957901040
	---	---	---	---	SG4-14-090-00-E	957901050
	---	---	---	---	SG4-14-105-00-E	957901060
	---	---	---	---	SG4-14-120-00-E	957901070
	---	---	---	---	SG4-14-135-00-E	957901080
	---	---	---	---	SG4-14-150-00-E	957901090
	---	---	---	---	SG4-14-165-00-E	957901100
	---	---	---	---	SG4-14-180-00-E	957901110
HAND PROTECTION	SG2-30-015-00-X	957801000	SG2-30-015-00-E-C	957801340	SG4-30-015-00-E	957901120
	SG2-30-030-00-X	957801010	SG2-30-030-00-E-C	957801350	SG4-30-030-00-E	957901130
	SG2-30-045-00-X	957801020	SG2-30-045-00-E-C	957801360	SG4-30-045-00-E	957901140
	SG2-30-060-00-X	957801030	SG2-30-060-00-E-C	957801370	SG4-30-060-00-E	957901150
	SG2-30-075-00-X	957801040	SG2-30-075-00-E-C	957801380	SG4-30-075-00-E	957901160
	SG2-30-090-00-X	957801050	SG2-30-090-00-E-C	957801390	SG4-30-090-00-E	957901170
	SG2-30-105-00-X	957801060	SG2-30-105-00-E-C	957801400	SG4-30-105-00-E	957901180
	SG2-30-120-00-X	957801070	SG2-30-120-00-E-C	957801410	SG4-30-120-00-E	957901190
	SG2-30-135-00-X	957801080	SG2-30-135-00-E-C	957801420	SG4-30-135-00-E	957901200
	SG2-30-150-00-X	957801090	SG2-30-150-00-E-C	957801430	SG4-30-150-00-E	957901210
	SG2-30-165-00-X	957801100	SG2-30-165-00-E-C	957801440	SG4-30-165-00-E	957901220
	SG2-30-180-00-X	957801110	SG2-30-180-00-E-C	957801450	SG4-30-180-00-E	957901230
PRESENCE/ARM DETECTION	SG2-50-030-00-X	957801120	SG2-50-030-00-E-C	957801460	---	---
	SG2-50-045-00-X	957801130	SG2-50-045-00-E-C	957801470	---	---
	SG2-50-060-00-X	957801140	SG2-50-060-00-E-C	957801480	---	---
	SG2-50-075-00-X	957801150	SG2-50-075-00-E-C	957801490	---	---
	SG2-50-090-00-X	957801160	SG2-50-090-00-E-C	957801500	---	---
	SG2-50-105-00-X	957801170	SG2-50-105-00-E-C	957801510	---	---
	SG2-50-120-00-X	957801180	SG2-50-120-00-E-C	957801520	---	---
	SG2-50-135-00-X	957801190	SG2-50-135-00-E-C	957801530	---	---
	SG2-50-150-00-X	957801200	SG2-50-150-00-E-C	957801540	---	---
	SG2-50-165-00-X	957801210	SG2-50-165-00-E-C	957801550	---	---
	SG2-50-180-00-X	957801220	SG2-50-180-00-E-C	957801560	---	---
	SG2-90-030-00-X	957801230	SG2-90-030-00-E-C	957801570	---	---
	SG2-90-045-00-X	957801240	SG2-90-045-00-E-C	957801580	---	---
	SG2-90-060-00-X	957801250	SG2-90-060-00-E-C	957801590	---	---
	SG2-90-075-00-X	957801260	SG2-90-075-00-E-C	957801600	---	---
	SG2-90-090-00-X	957801270	SG2-90-090-00-E-C	957801610	---	---
	SG2-90-105-00-X	957801280	SG2-90-105-00-E-C	957801620	---	---
	SG2-90-120-00-X	957801290	SG2-90-120-00-E-C	957801630	---	---
	SG2-90-135-00-X	957801300	SG2-90-135-00-E-C	957801640	---	---
	SG2-90-150-00-X	957801310	SG2-90-150-00-E-C	957801650	---	---
SG2-90-165-00-X	957801320	SG2-90-165-00-E-C	957801660	---	---	
SG2-90-180-00-X	957801330	SG2-90-180-00-E-C	957801670	---	---	

## CABLE ORDER CODES

	TRANSMITTER CABLE	LENGTH (M)	ORDER CODE
SG2 BASE [ SG2-xx-xxx-00-X ]  SG2 EXTENDED [ SG2-xx-xxx-00-E-C ]  SG4 BASE [ SG4-xx-xxx-00-E ]	CS-A1-02-U-03	3	95ASE1120
	CS-A1-02-U-05	5	95ASE1130
	CS-A1-02-U-10	10	95ASE1140
	CS-A1-02-U-15	15	95ASE1150
	CS-A1-02-U-25	25	95ASE1160
	RECEIVER CABLE	LENGTH (M)	ORDER CODE
SG2 BASE [ SG2-xx-xxx-00-X ]	CS-A1-03-U-03	3	95ASE1170
	CS-A1-03-U-05	5	95ASE1180
	CS-A1-03-U-10	10	95ASE1190
	CS-A1-03-U-15	15	95ASE1200
	CS-A1-03-U-25	25	95ASE1210
SG2 EXTENDED [ SG2-xx-xxx-00-E-C ]  SG4 BASE [ SG4-xx-xxx-00-E ]	CS-A1-06-U-03	3	95ASE1220
	CS-A1-06-U-05	5	95ASE1230
	CS-A1-06-U-10	10	95ASE1240
	CS-A1-06-U-15	15	95ASE1250
	CS-A1-06-U-25	25	95ASE1260

### NOTES

All cables have axial connectors

# SAFETY SENSORS

# SG BODY COMPACT BASE SG BODY COMPACT MUTING



*Body access detection*

*Perimeter control*

*Rapid solution for access control with muting*

*Easy installation and alignment*

*L and T muting models provided with Retroreflective Muting Arms*

- 2, 3, 4 beams for body protection
- Controlled heights 500, 800, 900 and 1200 mm
- Long operating distance: up to 50 m
- Simple configuration through DIP switches
- Integrated muting lamp (only muting models)



	FINGER	HAND	ARM	BODY
TYPE 2				▪
TYPE 4				▪

## SG2-S2-050-PP-E

TYPE	
2	Type 2
4	Type 4

BEAMS AND MUTING ARMS	
S2	2 Beams
S3	3 Beams
S4	4 Beams
T2	2 Beams with T muting arms (RRX)
T3	3 Beams with T muting arms (RRX)
L2	2 Beams with L muting arms (RRX)
L3	3 Beams with L muting arms (RRX)

MONITORED HEIGHT	
050	500 mm (2 beams)
080	800 mm (3 beams)
090	900 mm (4beams)
120	1200 mm (4 beams)

VERSION	
E	Base: without muting function
W	Muting: with muting function



### CHARACTERISTICS

	SG2 BODY COMPACT BASE [ SG2-Sx-xxx-PP-E ]	SG2 BODY COMPACT MUTING [ SG2-S/L/Tx-xxx-PP-W ]	SG4 BODY COMPACT BASE [ SG4-Sx-xxx-PP-E ]	SG4 BODY COMPACT MUTING [ SG4-S/L/Tx-xxx-PP-W ]
<b>GENERAL DATA</b>				
Type (EN61496-1-2)	2		4	
PL (EN ISO 13849-1)	c		e	
SIL (IEC 61508)	1		3	
Resolution	315 mm (4 beams) 415 mm (3 and 4 beams) 515 mm (2 beams)			
Protected height	515 mm (2 beams) 815 mm (3 beams) 915 mm or 1215 (4 beams)			
Operating distance	0.5 ...50 m			
Retroreflective muting arms operating distance (included in L and T versions)	---	0.5 ... 3 m	---	0.5 ... 3 m
Emitter-Receiver muting arms operating distance	---	0.5 ... 7 m	---	0.5 ... 7 m
<b>ELECTRICAL DATA</b>				
Power supply (Vdd)	24 Vdc ± 20%			
Outputs	2 PNP			
Output current	0.5 A max/each output			
Capacitive load	65 nF max at 25°C			
Response time	14 ... 16 ms depending on model <sup>A</sup>			
Cables length (for power supply)	50 m max.			
<b>MECHANICAL AND ENVIRONMENTAL DATA</b>				
Operating temperature	0 ...+55 °C			
Humidity	15 ... 95 % (no condensation)			
Mechanical protection	IP 65 (EN 60529)			
<b>FUNCTIONS</b>				
	Test input			
	Manual/Automatic restart			
	External Device Monitoring (EDM)			
Muting type (Selectable with DIP-sw) <sup>A</sup>	---	T-Muting/L-Muting	---	T-Muting/L-Muting
Muting time-out (Selectable with DIP-sw) <sup>A</sup>	---	10 min. or ∞	---	10 min. or ∞
	---	Override	---	Override

#### NOTES

<sup>A</sup> For detailed informations refer to related Product Datasheet or Manual

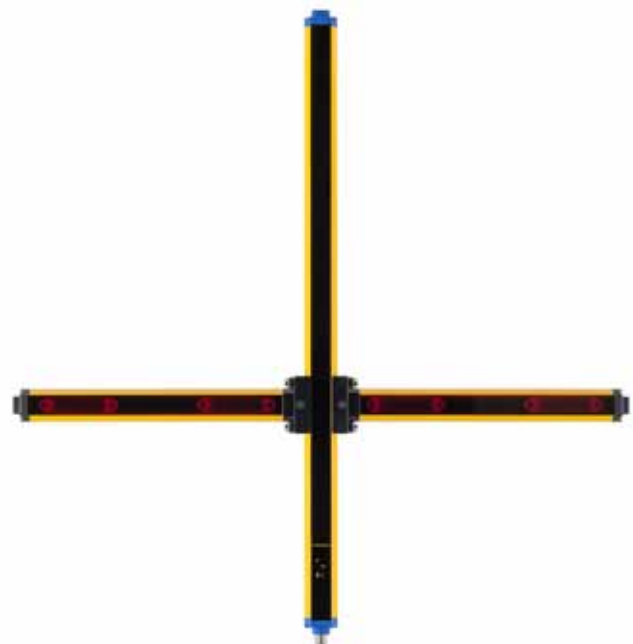

### CONNECTIONS

	SG2 BODY COMPACT BASE [ SG2-Sx-xxx-PP-E ]	SG4 BODY COMPACT BASE [ SG4-Sx-xxx-PP-E ]	SG2 BODY COMPACT MUTING [ SG2-S/L/Tx-xxx-PP-W ]	SG4 BODY COMPACT MUTING [ SG4-S/L/Tx-xxx-PP-W ]
EMITTER MAIN CONNECTOR		M12, 4 poles, male  1 = Brown = 24Vdc 3 = Blue = 0 V		
EMITTER SECONDARY CONNECTOR	---		M12, 5 poles, male  1 = Brown = 24 Vdc 3 = Blue = 0 V	
RECEIVER MAIN CONNECTOR	M12, 8 poles, male  1 = white = TEST/START 2 = brown = 24 Vdc 4 = yellow = EDM 5 = grey = OSSD 1 6 = pink = OSSD 2 7 = blue = 0 V		M12, 8 poles, male  1 = white = TEST/START 2 = brown = 24 VDC 3 = green = OVERRIDE 1 4 = yellow = EDM 5 = grey = OSSD 1 6 = pink = OSSD 2 7 = blue = 0 V 8 = red = OVERRIDE 2	
RECEIVER SECONDARY CONNECTOR	---		M12, 5 poles, male  1 = Brown = 24 Vdc 2 = White = MUTING2 3 = Blue = 0 V 4 = Black = MUTING1	

### ACCESSORIES

	SG2 BODY COMPACT BASE SG4 BODY COMPACT BASE [ SG2/4-Sx-xxx-PP-E ]	SG2 BODY COMPACT MUTING SG4 BODY COMPACT MUTING [ SG2/4-S/L/Tx-xxx-PP-W ]
	<b>BRACKETS</b>	
Standard angled brackets (4 pcs) <sup>A</sup>	ST-KSTD (included)	
Rotating brackets (4 pcs)	ST-K4ROT-SG BODY COMPACT	
Antivibration support (4 pcs/6 pcs) <sup>C</sup>	ST-K4AV ST-K6AV	
Orientable support (4 pcs/6 pcs) <sup>C</sup>	ST-K4OR ST-K6OR	
Plastic brackets (4 pcs/6 pcs) <sup>C</sup>	ST-KP4MP ST-KP6MP	
	<b>PROTECTION TUBES AND STANDS</b>	
IP67/IP69K Tubes	---	
Protective Stands	SG-PSB series <sup>B</sup>	
Stand Plate for SG-PSB	SG-P	
Protective Stands Mounting Brackets (4 pcs/6 pcs) <sup>C</sup>	ST-PS4-SG-SE ST-PS6-SG-SE	
Floor Columns	SE-S Series	
	<b>MIRRORS</b>	
Protective stands with single mirrors	SG-PSM series	
Deviating Mirrors mounting kit for SG-PSB	ST-PS-DM	
Deviating Mirrors	SG-DM series	
Mirror Mounting Bracket	ST-DM	
	<b>SAFETY UNITS</b>	
Safety Unit	SE-SR2	
EDM Relay Box <sup>D</sup>	CS ME-03VU24-Y14	
Safety control unit for single beams and SLC	SG-BWS-T4-MT	
	<b>ALIGNMENT TOOL</b>	
LASER Pointer	SG-LP	
	<b>ACCESSORIES FOR MUTING</b>	
Muting arms, brackets and cables	---	See page 77
Muting connection box	---	SG-SRT-1 <sup>D</sup>
External muting lamps	---	LMS series

#### NOTES

<sup>A</sup> 1200 mm models are provided with 6 pcs standard brackets

<sup>B</sup> Not possible with T or L muting arms mounted

<sup>C</sup> Use 6 brackets for light curtains with length  $\geq$  1200 mm

<sup>D</sup> When using EDM Relay Box or Muting connection box, connect EDM input, and be sure EDM function is active on the safety light curtain

# SAFETY SENSORS | SG BODY COMPACT BASE SG BODY COMPACT MUTING

## DIMENSIONS (mm)

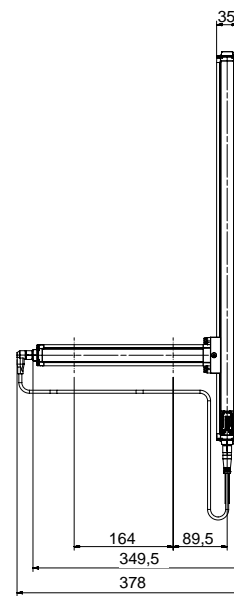
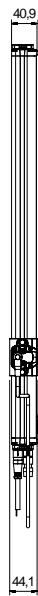
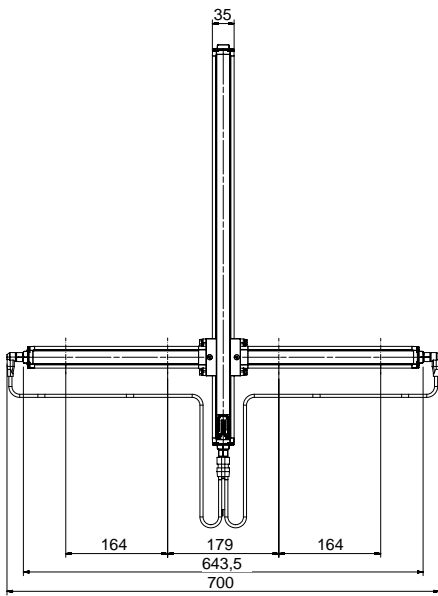
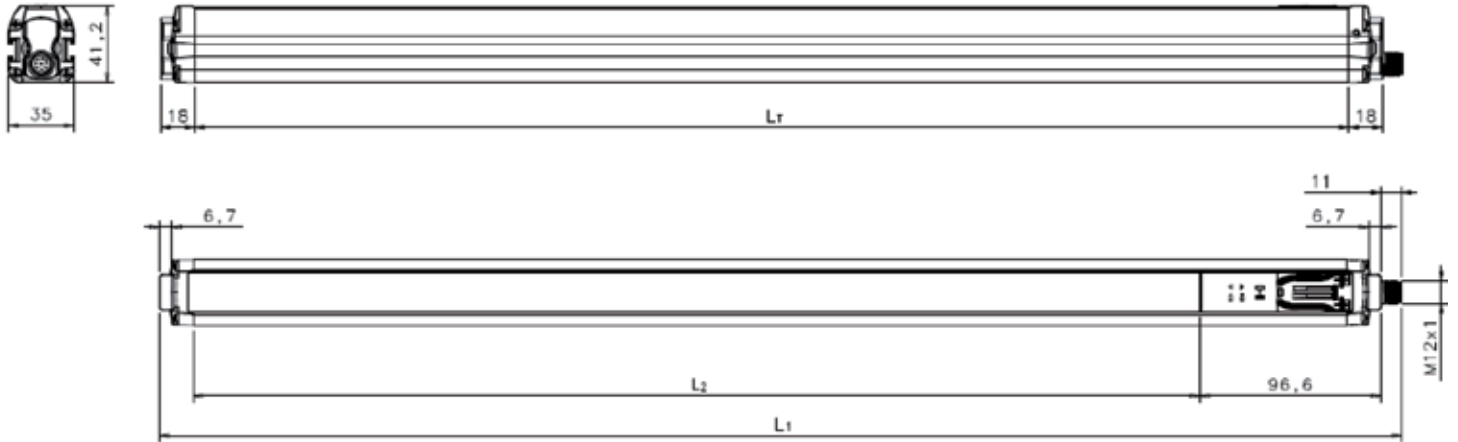

MODEL	L1 (mm)	L2 (mm)	A (mm)	B (mm)	C (mm)
SGx-S/L/Tx-050-PP-E	662	538.4	120-260	653	700
SGx-S/L/Tx-080-PP-E	962	838.4	120-260	953	1000
SGx-S/L/Tx-090-PP-E	1062.5	938.4	120-260	1053	1100
SGx-S/L/Tx-120-PP-E	1362.5	1238.4	120-260	1353	1400

## INDICATORS

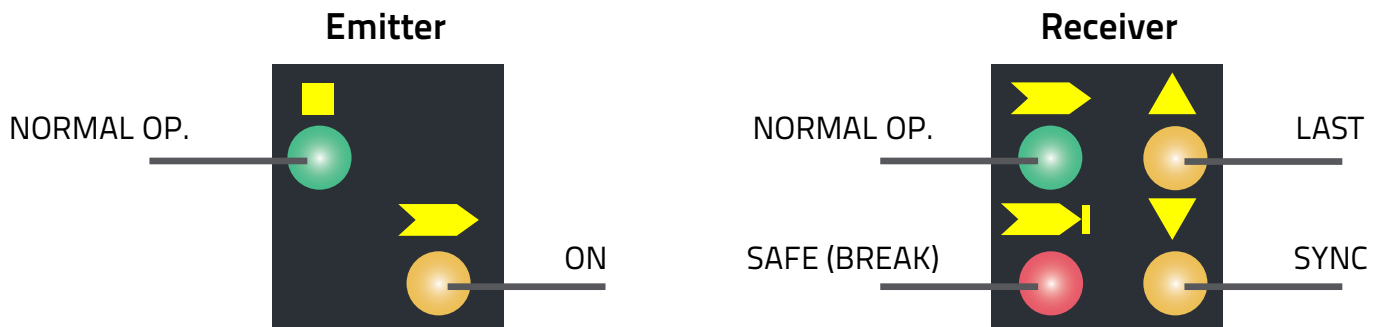

## DIP SWITCHES

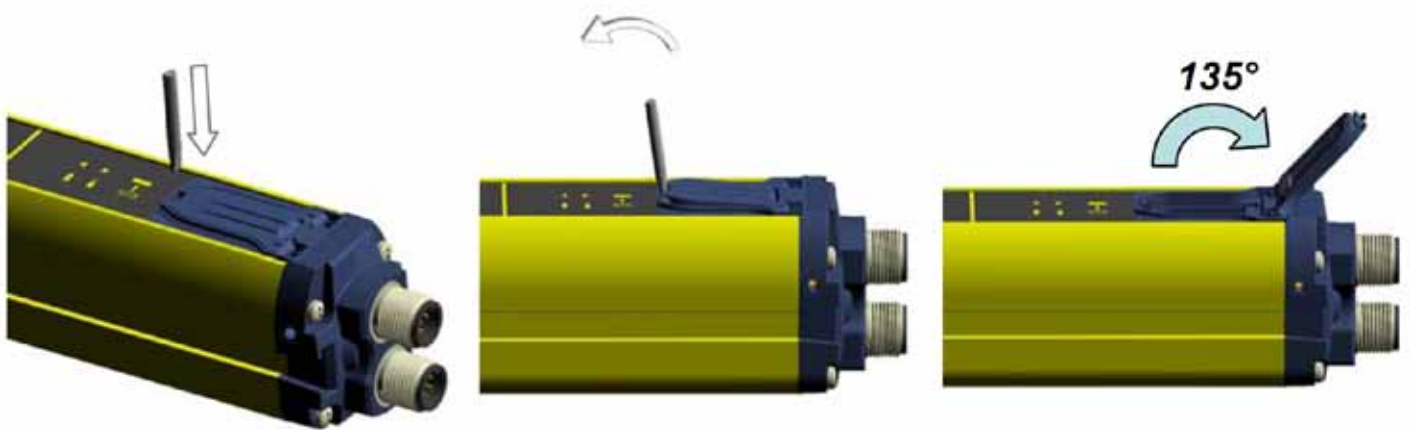

### AVAILABLE MODELS AND ORDER CODES

		SG2 BODY COMPACT BASE [ SG2-Sx-xxx-PP-E ]	ORDER CODE	SG4 BODY COMPACT BASE [ SG4-SX-XXX-PP-E ]	ORDER CODE	
BODY PROTECTION WITHOUT MUTING		SG2-S2-050-PP-E	957851000	SG4-S2-050-PP-E	957851040	
		SG2-S3-080-PP-E	957851010	SG4-S3-080-PP-E	957851050	
		SG2-S4-090-PP-E	957851020	SG4-S4-090-PP-E	957851060	
		SG2-S4-120-PP-E	957851030	SG4-S4-120-PP-E	957851070	
BODY PROTECTION WITH INTEGRATED MUTING	WITHOUT MUTING ARMS	SG2 BODY COMPACT MUTING [ SG2-S/L/TX-XXX-PP-W ]	ORDER CODE	SG4 BODY COMPACT MUTING [ SG4-S/L/TX-XXX-PP-W ]	ORDER CODE	
			SG2-S2-050-PP-W	957851080	SG4-S2-050-PP-W	957851160
			SG2-S3-080-PP-W	957851090	SG4-S3-080-PP-W	957851170
			SG2-S4-090-PP-W	957851100	SG4-S4-090-PP-W	957851180
		SG2-S4-120-PP-W	957851110	SG4-S4-120-PP-W	957851190	
	WITH L MUTING ARMS		SG2-L2-050-PP-W	957851120	SG4-L2-050-PP-W	957851200
			SG2-L3-080-PP-W	957851130	SG4-L3-080-PP-W	957851210
	WITH T MUTING ARMS		SG2-T2-050-PP-W	957851140	SG4-T2-050-PP-W	957851220
			SG2-T3-080-PP-W	957851150	SG4-T3-080-PP-W	957851230

### CABLE ORDER CODES

	TRANSMITTER CABLE (MAIN CONNECTOR)	LENGTH (m)	CONNECTOR	ORDER CODE
SG BODY COMPACT BASE [ SG2-Sx-xxx-PP-E ] [ SG4-Sx-xxx-PP-E ]	CV-A1-22-B-03	3	Axial	95ACC1480
	CV-A1-22-B-05	5	Axial	95ACC1490
	CV-A1-22-B-10	10	Axial	95ACC1500
	CV-A1-22-B-15	15	Axial	95ACC2070
	CV-A1-22-B-25	25	Axial	95ACC2090
SG BODY COMPACT MUTING [ SG2-S/L/Tx-xxx-PP-W ] [ SG4-S/L/Tx-xxx-PP-W ]	CV-A2-22-B-03	3	Radial	95ACC1540
	CV-A2-22-B-05	5	Radial	95ACC1550
	CV-A2-22-B-10	10	Radial	95ACC1560
	RECEIVER CABLE (MAIN CONNECTOR)	LENGTH (m)	CONNECTOR	ORDER CODE
SG BODY COMPACT BASE [ SG2-Sx-xxx-PP-E ] [ SG4-Sx-xxx-PP-E ]	CV-A1-26-B-03	3	Axial	95ACC1510
	CV-A1-26-B-05	5	Axial	95ACC1520
	CV-A1-26-B-10	10	Axial	95ACC1530
	CV-A1-26-B-15	15	Axial	95ACC2080
	CV-A1-26-B-25	25	Axial	95ACC2100
SG BODY COMPACT MUTING [ SG2-S/L/Tx-xxx-PP-W ] [ SG4-S/L/Tx-xxx-PP-W ]	CV-A2-26-B-03	3	Radial	95ACC1600
	CV-A2-26-B-05	5	Radial	95ACC1610
	CV-A2-26-B-10	10	Radial	95ACC1620
	TRANSMITTER CABLE (SECONDARY CONNECTOR)	LENGTH (m)	CONNECTOR	ORDER CODE
SG BODY COMPACT MUTING (LINEAR) [ SG2-Sx-xxx-PP-W ] [ SG4-Sx-xxx-PP-W ]	CS-A1-03-U-03	3	Axial	95ASE1170
	CS-A1-03-U-05	5	Axial	95ASE1180
	CS-A1-03-U-10	10	Axial	95ASE1190
	CS-A1-03-U-15	15	Axial	95ASE1200
	CS-A1-03-U-25	25	Axial	95ASE1210

#### IMPORTANT NOTES

- 1) The cables for the secondary connector of SG BODY COMPACT MUTING T and L are provided within the package
- 2) In order to install SG4 EXTENDED or SG2 MUTING in place of SE2 BODY and SE4 BODY safety light curtains, without changing any wiring, it can be used the cable CV-Y3-36-B-002 (order n. 95A252900) for receiver. All functions of SE will be available, except Override. SG BODY COMPACT MUTING has integrated muting lamp, therefore any external muting lamp connected that was connected to SE light curtain, will not lit. Ensure that the integrated muting lamp of SG BODY COMPACT MUTING will be visible.





# SAFETY SENSORS

## SG BODY BIG BASE SG BODY BIG MUTING



*Robust housing for harsh environments  
Long operating range for perimeter control  
Rapid solution for access control with muting  
Easy installation and alignment*



- 2, 3, 4 beams for body protection
- 40 mm resolution for arm protection and presence detection
- Controlled heights 500, 800, 900 and 1200 mm
- Long operating distance: up to 60 m
- Simple configuration through DIP switches
- Integrated muting lamp (only muting models)
- Anti-interference coding
- External muting enable signal
- Edged or triggered muting dependent override



	FINGER	HAND	ARM	BODY
TYPE 2				▪
TYPE 4			▪	▪

### SG2-B2-050-00-E

TYPE	
2	Type 2
4	Type 4

MONITORED HEIGHT	
050	500 mm (2 beams)
080	800 mm (3 beams)
090	900 mm (4beams)
120	1200 mm (4 beams)

VERSION	
E	Base: without muting function
W-C	Muting: with integrated muting function

BEAMS AND RANGE	
B2	2 Beams
B3	3 Beams
B4	4 Beams
BSR2	2 Beams Short Range (only type 4)
BSR3	3 Beams Short Range (only type 4)
BSR4	4 Beams Short Range (only type 4)
BLR2	2 Beams Long Range (only type 4)
BLR3	3 Beams Long Range (only type 4)
BLR4	4 Beams Long Range (only type 4)

### SG4-40-060-00-E

MONITORED HEIGHT	
060	660 mm
090	960 mm
120	1260 mm

### CHARACTERISTICS

	SG2 BODY BIG BASE [ SG2-Bx-xxx-00-E ]	SG2 BODY BIG MUTING [ SG2-Bxxx-xxx-00-W-C ]	SG4 BODY BIG BASE [ SG4-Bx-xxx-00-E ]	SG4 BODY BIG MUTING [ SG4-Bxxx-xxx-00-W-C ]	SG4 LONG RANGE BASE [ SG4-40-xxx-00-E ]
<b>GENERAL DATA</b>					
Type (EN61496-1-2)	2		4		
PL (EN ISO 13849-1)	c		e		
SIL (IEC 61508)	1		3		
Resolution	319,75 mm (4 beams) 419,75 mm (3 and 4 beams) 519,75 mm (2 beams)				40 mm
Operating distance	0.5 ... 60 m		6 ... 60 m	0.5 ... 30 m (Short Range model) 6 ... 60 m (Long Range model)	6 ... 60 m
Retroreflective muting arms operating distance (not included)	---	0.5 ... 3 m	---	0.5 ... 3 m (Only for Short Range model)	---
Emitter-Receiver muting arms operating distance	---	0.5 ... 7 m	---	0.5 ... 7 m	---
Protected height	500 mm (2 beams) 800 mm (3 beams) 900 mm or 1200 (4 beams)				660 mm 960 mm 1260 mm
<b>ELECTRICAL DATA</b>					
Power supply (Vdd)	24 Vdc ± 20%				
Outputs	2 PNP				
Output current	0.5 A max/each output				
Capacitive load	2,2 uF max at 25°C				
Response time	11 ... 24 ms depending on model <sup>A</sup>				20 ... 24 ms depending on model <sup>A</sup>
Cables length (for power supply)	70 m max.				
<b>MECHANICAL AND ENVIRONMENTAL DATA</b>					
Operating temperature	0 ... +55 °C				
Humidity	15 ... 95 % (no condensation)				
Mechanical protection	IP 65 (EN 60529)				
<b>FUNCTIONS</b>					
Test input					
Manual/Automatic restart					
External Device Monitoring (EDM)					
Coding selection with DIP-SW					
---	T-Muting/L-Muting	---	T-Muting/L-Muting	---	---
---	Muting timeout: 10 min. or ∞	---	Muting timeout: 10 min. or ∞	---	---
---	Integrated muting lamp	---	Integrated muting lamp	---	---
---	Override	---	Override	---	---
---	Muting enable input	---	Muting enable input	---	---
---	Override status output	---	Override status output	---	---
---	Muting lamp output	---	Muting lamp output	---	---

#### NOTES

<sup>A</sup> For detailed informations refer to related Product Datasheet or Manual

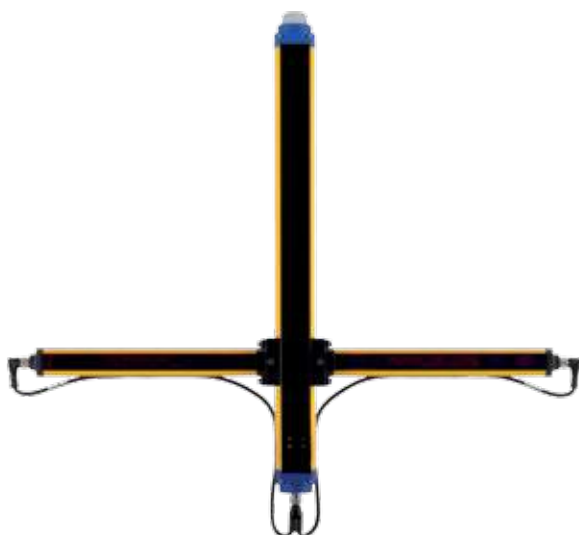

## CONNECTIONS

	SG BODY BIG BASE [ SG2/4-Bx-xxx-00-E ] SG4 LONG RANGE BASE [ SG4-40-xxx-00-E ]	SG BODY BIG MUTING [ SG2/4-Bxxx-xxx-00-W-C ]
EMITTER MAIN CONNECTOR	M12, 5 poles, male 1 = brown = 24Vdc; 2 = white = TEST; 3 = blue = 0V; 4 = black = EARTH	M12, 5 poles, male 1 = brown = 24Vdc; 3 = blue = 0V
EMITTER SECONDARY CONNECTOR	---	---
RECEIVER MAIN CONNECTOR	M12, 8 poles, male 1 = white = RESET/RESTART/RESTART MODE; 2 = brown = 24Vdc; 3 = green = EDM ENABLE; 4 = yellow = EDM; 5 = grey = OSSD1; 6 = pink = OSSD2; 7 = blue = 0V; 8 = red = EARTH	M12 12-pole connector 1 = Brown = 24Vdc; 2 = Blue = 0V; 3 = White = RESET/RESTART/RESTART MODE; 4 = Green = OVERRIDE 1; 5 = Pink = OSSD 2; 6 = Yellow = EDM; 7 = Black = MUTING ENABLE; 8 = Grey = OSSD 1; 9 = Red = OVERRIDE 2; 10 = Violet = LAMP OUTPUT; 11 = Grey-Pink = OVERRIDE STATUS; 12 = Red-Blue = EARTH
RECEIVER SECONDARY CONNECTOR	---	M12, 5 poles, male 1 = brown = 24Vdc; 2 = white = MUTING2; 3 = blue = 0V; 4 = black = MUTING 1

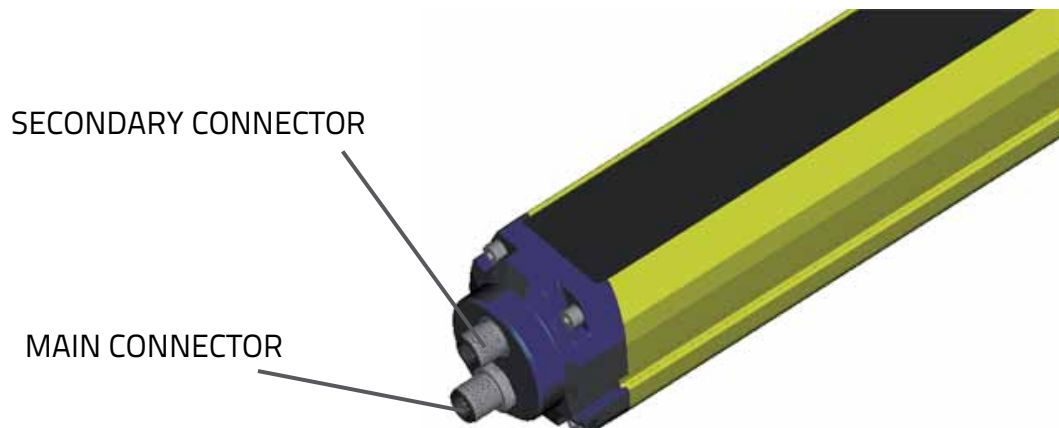

### ACCESSORIES

	SG BODY BIG BASE [ SG2/4-Bx-xxx-00-E ]	SG BODY BIG MUTING [ SG2/4-Bxxx-xxx-00-W-C ]	SG4 LONG RANGE BASE [ SG4-40-xxx-00-E ]
<b>BRACKETS</b>			
Included with the light curtain	None		
Standard angled brackets (4 pcs)	ST-K4STD-SG-BODY BIG		
Rear fixing bracket mounting (4 pcs)	ST-K4REAR-SG BODY BIG		
Rotating brackets (4 pcs)	ST-K4ROT-SG BODY BIG		
Antivibration support (4 pcs/6 pcs) <sup>C</sup>	ST-K4AV ST-K6AV		
Plastic brackets (4 pcs/6 pcs) <sup>C</sup>	ST-KP4MP ST-KP6MP		
<b>PROTECTION TUBES, STANDS</b>			
IP67/IP69K Tubes	---		
Protective Stands	SG-PSB series <sup>B</sup>		
Stand Plate for SG-PSB	SG-P		
Protective Stands Mounting Brackets (4 pcs/6 pcs) <sup>C</sup>	ST-PS4-SG BODY ST-PS6-SG BODY		
Floor Columns	SE-S Series		
<b>MIRRORS</b>			
Protective stands with single mirrors	SG-PSM series	---	
Deviating Mirrors mounting kit for SG-PSB	ST-PS-DM		
Deviating Mirrors	SG-DM series		
Mirror Mounting Bracket	ST-DM		
<b>SAFETY UNITS</b>			
Safety Unit	SE-SR2		
EDM Relay Box <sup>D</sup>	CS ME-03VU24-Y14		
Safety control unit for single beams and SLC	SG-BWS-T4-MT		
<b>ALIGNMENT TOOL</b>			
LASER Pointer	SG-LP		
<b>ACCESSORIES FOR MUTING</b>			
Muting arms, brackets and cables	---	See page 76	---
Muting connection box <sup>D</sup>	---	SG-SRT-1	---
External muting lamps	---	LMS series	---

#### NOTES

<sup>B</sup> Not possible with T or L muting arms mounted

<sup>C</sup> Use 6 brackets for light curtains with length  $\geq 1200$  mm

<sup>D</sup> When using EDM Relay Box or Muting connection box, connect EDM input, and be sure EDM function is active on the safety light curtain

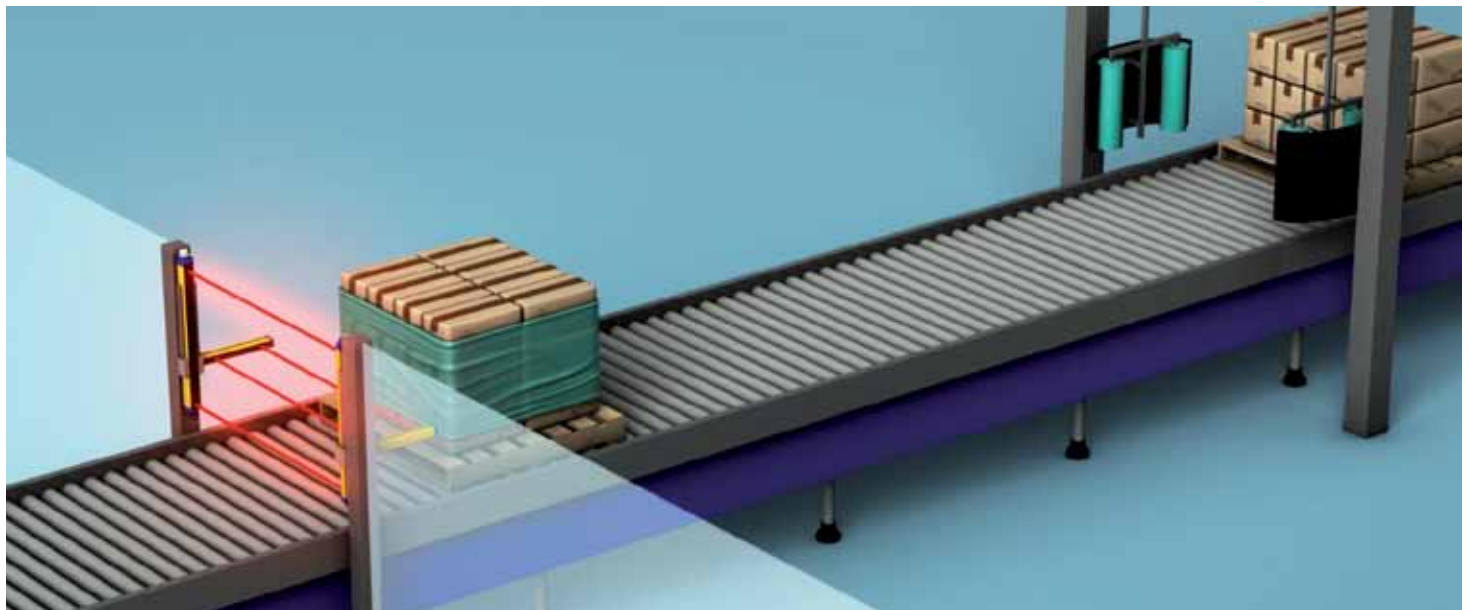

# SAFETY SENSORS | SG BODY BIG BASE SG BODY BIG MUTING

## DIMENSIONS (mm)

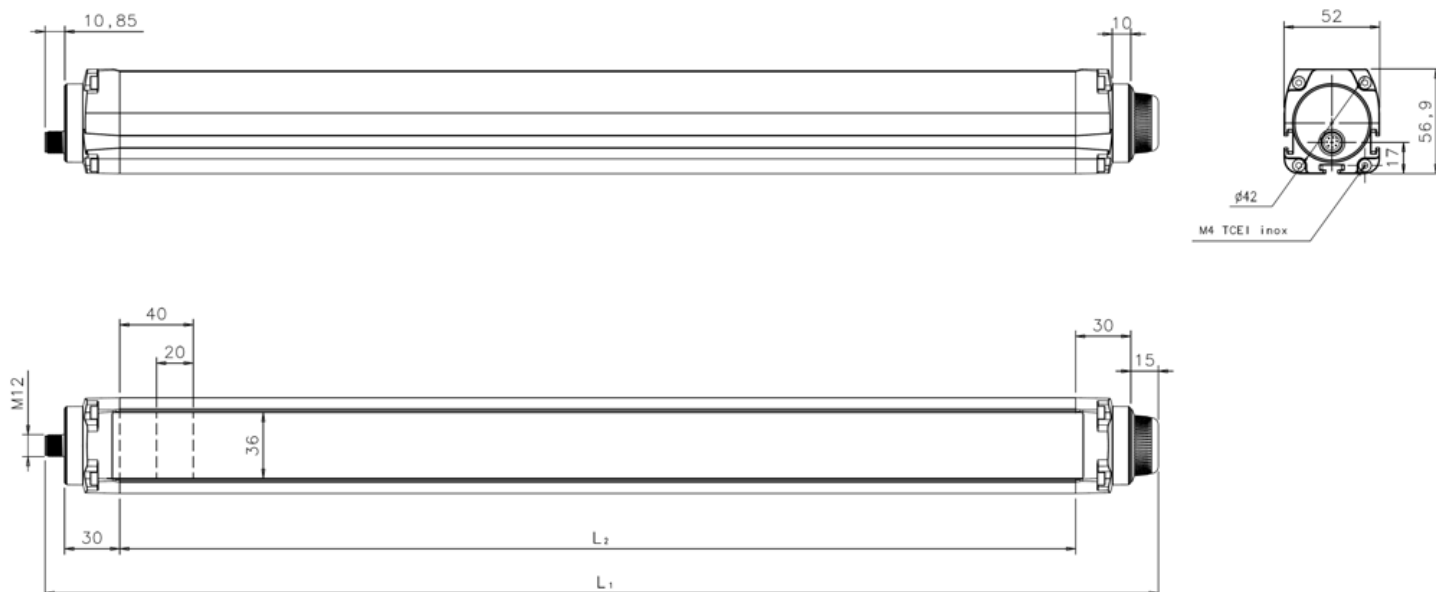

MODEL	L1 [mm]	L2 [mm]
SGx-B2-050-00-E	606,35	520,5
SGx-B3-080-00-E	906,35	820,5
SGx-B4-090-00-E	1006,35	920,5
SGx-B4-120-00-E	1306,35	1220,5
SG4-40-060-00-E	783,35	700,5
SG4-40-090-00-E	1083,35	1000,5
SG4-40-120-00-E	1383,35	1300,5
SGx-Byy2-050-00-W-C	609,35	520,5
SGx-Byy3-080-00-W-C	909,35	820,5
SGx-Byy4-090-00-W-C	1009,35	920,5
SGx-Byy4-120-00-W-C	1309,35	1220,5

## INDICATORS

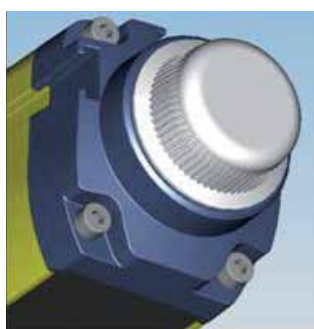



# SAFETY SENSORS

SG BODY BIG BASE  
SG BODY BIG MUTING

## AVAILABLE MODELS AND ORDER CODES

BODY PROTECTION					ARM PROTECTION PRESENCE DETECTION						
	WITHOUT MUTING			WITH INTEGRATED MUTING							
	SG2 BODY BIG BASE [ SG2-BX-XXX-OO-E ]	ORDER CODE		SG4 BODY BIG BASE [ SG4-BX-XXX-OO-E ]	ORDER CODE						
WITHOUT MUTING	SG2-B2-050-00-E	957851240	WITHOUT MUTING	SG4-B2-050-00-E	957851280	LONG RANGE	SG4-40-060-00-E	957851570			
	SG2-B3-080-00-E	957851250		SG4-B3-080-00-E	957851290		SG4-40-090-00-E	957851580			
	SG2-B4-090-00-E	957851260		SG4-B4-090-00-E	957851300		SG4-40-120-00-E	957851590			
	SG2-B4-120-00-E	957851270		SG4-B4-120-00-E	957851310		---	---			
WITH INTEGRATED MUTING	SG2 BODY BIG MUTING [ SG2-BXXX-XXX-OO-W-C ]	ORDER CODE	WITH INTEGRATED MUTING	SG4 BODY BIG MUTING [ SG4-BXXX-XXX-OO-W-C ]	ORDER CODE						
	SG2-B2-050-00-W-C	957851320		SG4-B5R2-050-00-W-C	957851400				---	---	
	SG2-B3-080-00-W-C	957851330		SG4-B5R3-080-00-W-C	957851410				---	---	
	SG2-B4-090-00-W-C	957851340		SG4-B5R4-090-00-W-C	957851420				---	---	
	SG2-B4-120-00-W-C	957851350		SG4-B5R4-120-00-W-C	957851430				---	---	
	---	---		LONG RANGE	SG4-BLR2-050-00-W-C				957851360	---	---
	---	---			SG4-BLR3-080-00-W-C				957851370	---	---
	---	---			SG4-BLR4-090-00-W-C				957851380	---	---
---	---	SG4-BLR4-120-00-W-C	957851390		---	---					

## CABLE ORDER CODES

	TRANSMITTER CABLE (MAIN CONNECTOR)	LENGTH (m)	ORDER CODE	
SG BODY BIG BASE [ SG2-Bx-xxx-OO-E ] [ SG4-Bx-xxx-OO-E ]	CS -A1-03-U-03	3	95ASE 1170	
	CS -A1-03-U-05	5	95ASE 1180	
	SG4 LONG RANGE BASE [ SG4-40-xxx-OO-E ]	CS -A1-03-U-10	10	95ASE 1190
		CS -A1-03-U-15	15	95ASE 1200
	SG BODY BIG MUTING [ SG2-Bx-xxx-OO-W-C ] [ SG4-Bxxx-xxx-OO-W-C ]	CS -A1-03-U-25	25	95ASE 1210
		CS -A1-03-U-50	50	95A252700
	RECEIVER CABLE (MAIN CONNECTOR)	LENGTH (m)	ORDER CODE	
SG BODY BIG BASE [ SG2-Bx-xxx-OO-E ] [ SG4-Bx-xxx-OO-E ]	CS -A1-06-U-03	3	95ASE1220	
	CS -A1-06-U-05	5	95ASE1230	
	CS -A1-06-U-10	10	95ASE1240	
SG4 LONG RANGE BASE [ SG4-40-xxx-OO-E ]	CS -A1-06-U-15	15	95ASE1250	
	CS -A1-06-U-25	25	95ASE1260	
	CS -A1-06-U-50	50	95A252710	
SG BODY BIG MUTING [ SG2-Bx-xxx-OO-W-C ] [ SG4-Bxxx-xxx-OO-W-C ]	CS -A1-10-U-03	3	95A252720	
	CS -A1-10-U-05	5	95A252730	
	CS -A1-10-U-10	10	95A252740	
	CS -A1-10-U-15	15	95A252750	
	CS -A1-10-U-25	25	95A252760	
	CS -A1-10-U-50	50	95A252770	
	TRANSMITTER CABLE (SECONDARY CONNECTOR)	LENGTH (m)	ORDER CODE	
SG BODY BIG MUTING [ SG2-Bx-xxx-OO-W-C ] [ SG4-Bxxx-xxx-OO-W-C ]	RECEIVER CABLE (SECONDARY CONNECTOR)			
	CS -A1-03-U-03	3	95ASE 1170	
	CS -A1-03-U-05	5	95ASE 1180	
	CS -A1-03-U-10	10	95ASE 1190	
	CS -A1-03-U-15	15	95ASE 1200	
	CS -A1-03-U-25	25	95ASE 1210	
CS -A1-03-U-50	50	95A252700		

### NOTES

All cables have axial connectors

# SAFETY SENSORS

## SG BODY REFLECTOR BASE SG BODY REFLECTOR MUTING

*One active and one passive unit to reduce wiring and installation costs*

*Robust housing for harsh environments*

*Easy installation and alignment*

*Reflective muting arms included in L and T muting version*

*All advanced features associated to muting function*



- 2, 3, 4 beams for body protection
- Controlled heights 500, 800, 900 and 1200 mm
- Up to 8 m operating distance
- Simple configuration through DIP switches
- Integrated muting lamp (muting models)
- Anti-interference coding
- External muting enable signal
- Edged or triggered muting dependent override



	FINGER	HAND	ARM	BODY
TYPE 2				
TYPE 4				▪

### Active unit

# SG4-RB2L-050-00-W

TYPE		MUTING ARMS		MONITORED HEIGHT		VERSION	
4	Type 4	---	Linear version: no muting arms included	050	500 mm (2 beams)	E	Base: without integrated muting function
		L	L muting arms included	080	800 mm (3 beams)	W	Muting: with integrated muting function
		T	T muting arms included	090	900 mm (4beams)		
				120	1200 mm (4 beams)		

BEAMS AND RANGE	
2	2 Beams
3	3 Beams
4	4 Beams

### Passive unit

# SG4-RDB2L-090

TYPE		BEAMS AND RANGE		MUTING ARMS		MONITORED HEIGHT	
4	Type 4	2	2 Beams	---	Linear version: no muting arms included	---	500 mm (2 beams) or 800 mm (3 beams)
		3	3 Beams	L	L muting arms included	090	900 mm (4 beams)
		4	4 Beams	T	T muting arms included	120	1200 mm (4 beams)

### CHARACTERISTICS

	SG BODY REFLECTOR BASE [ SG4-RBx-xxx-00-E ] + [SG4-RDBx ]	SG BODY REFLECTOR MUTING [ SG4-RBx-xxx-00-W ] + [SG4-RDBx ] [SG4-RBxL/T-xxx-00-W] + [SG4-RDBxL/T ]
<b>GENERAL DATA</b>		
Type (EN61496-1)	4	
PL (EN ISO 13849-1)	e	
SIL (IEC 61508)	3	
Resolution	319,75 mm (4 beams) 419,75 mm (3 and 4 beams) 519,75 mm (2 beams)	
Protected height	500 mm (2 beams) 800 mm (3 beams) 900 mm or 1200 (4 beams)	
Operating distance	0.5 ... 8 m 0.5 ... 6.5 m (for SG4-RB4-090-00-E)	0.5 ... 8 m (for SG4-RBx-xxx-00-W) 0.5 ... 6.5 m (for SG4-RB4-090-00-W) 0.5 ... 3 m (for SG4-RBxL/T-00-W)
Retroreflective muting arms operating distance (included in T and L models)		0.5 ... 3 m
Emitter-Receiver muting arms operating distance (not included)	---	0.5 ... 7 m
<b>ELECTRICAL DATA</b>		
Power supply (Vdd)	24 Vdc ± 20%	
Outputs	2 PNP	
Output current	0.5 A max/each output	
Capacitive load	2,2 uF max at 25°C	
Response time	11 ... 12 ms depending on model <sup>A</sup>	
Cables length (for power supply)	70 m max.	
<b>MECHANICAL AND ENVIRONMENTAL DATA</b>		
Operating temperature	0 ...+55 °C	
Humidity	15 ... 95 % (no condensation)	
Mechanical protection	IP 65 (EN 60529)	
<b>FUNCTIONS</b>		
	Manual/Automatic restart	
	External Device Monitoring (EDM)	
	Coding selection with DIP-SW	
---		T-Muting/L-Muting
		Integrated muting lamp
---		Muting timeout: 10 min. or ∞
		Integrated muting lamp
---		Override
---		Muting enable input
---		Override status output
---		Muting filter
---		Externa muting lamp output

#### NOTES

<sup>A</sup> For detailed informations refer to related Product Datasheet or Manual

## CONNECTORS

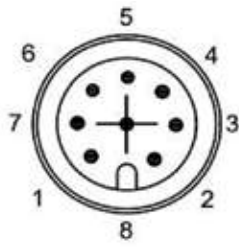
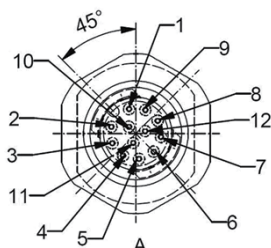
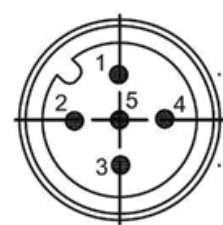
	SG BODY REFLECTOR BASE [ SG4-RBX-XXX-00-E ]	SG BODY REFLECTOR MUTING [ SG4-RBX-XXX-00-W ] [ SG4-RBXL/T-XXX-00-W ]
ACTIVE UNIT MAIN CONNECTOR	<p>M12, 8 poles, male</p> <p>1 = white = RESET/RESTART/RESTART MODE                      2 = brown = 24V                      3 = green = EDM ENABLE                      4 = yellow = EDM                      5 = grey = OSSD1                      6 = pink = OSSD2                      7 = blue = 0V                      8 = red = EARTH</p> 	<p>M12, 12 poles, male</p> <p>1 = brown = 24Vdc                      2 = blue = 0V                      3 = white = RESET/RESTART/RESTART MODE                      4 = green = OVERRIDE1                      5 = pink = OSSD2                      6 = yellow = EDM                      7 = black = MUTING ENABLE                      8 = grey = OSSD1                      9 = red = OVERRIDE2                      10 = violet = LAMP INPUT                      11 = grey-pink = OVERRIDE STATUS                      12 = red-blue = EARTH</p> 
ACTIVE UNIT SECONDARY CONNECTOR	<p>---</p> <p>---</p>	<p>M12, 5 poles, male</p> <p>1 = brown = 24Vdc                      2 = white = MUTING2                      3 = blue = 0V                      4 = black = MUTING1</p> 

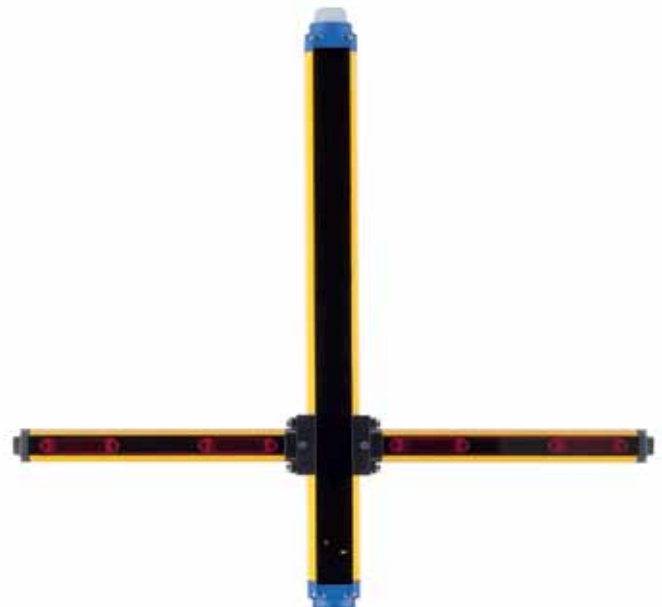
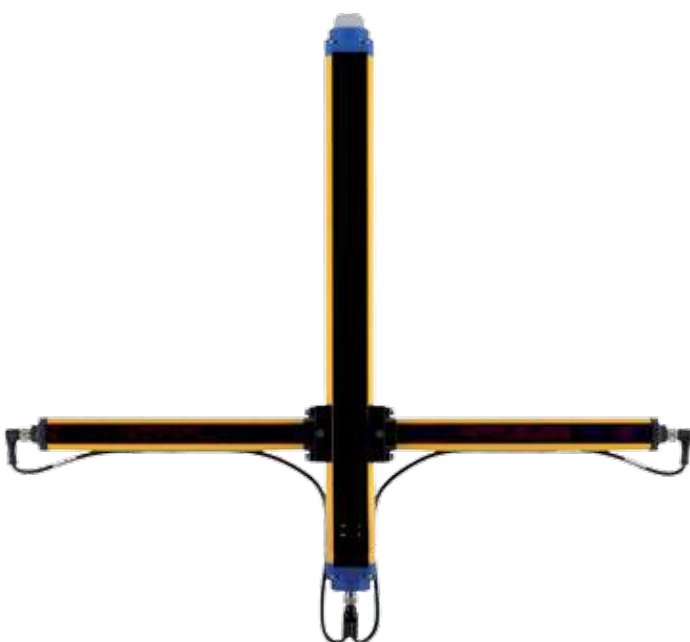

### ACCESSORIES

	SG BODY REFLECTOR BASE [ SG4-RBX-XXX-00-E ] + [SG4-RDBX ]	SG BODY REFLECTOR MUTING [ SG4-RBX-XXX-00-W ] + [SG4-RDBX ] [SG4-RBXL/T-XXX-00-W] + [SG4-RDBXL/T ]
	<b>BRACKETS</b>	
Included with the light curtain	None	
Standard angled brackets (4 pcs)	ST-K4STD-SG-BODY BIG	
Rear fixing bracket mounting (4 pcs)	ST-K4REAR-SG BODY BIG	
Rotating brackets (4 pcs)	ST-K4ROT-SG BODY BIG	
Antivibration support (4 pcs/6 pcs) <sup>B</sup>	ST-K4AV ST-K6AV	
Plastic brackets (4 pcs/6 pcs) <sup>B</sup>	ST-KP4MP ST-KP6MP	
	<b>PROTECTION TUBES, STANDS</b>	
IP67/IP69K Tubes	---	
Protective Stands	SG-PSB series <sup>A</sup>	
Stand Plate for SG-PSB	SG-P	
Protective Stands Mounting Brackets (4 pcs/6 pcs) <sup>B</sup>	ST-PS4-SG BODY ST-PS6-SG BODY	
Floor columns	SE-S Series	
	<b>SAFETY UNITS</b>	
Safety Unit	SE-SR2	
EDM Relay Box <sup>C</sup>	CS ME-03VU24-Y14	
Safety control unit for single beams and SLC	SG-BWS-T4-MT	
	<b>ALIGNMENT TOOL</b>	
LASER Pointer	SG-LP	
	<b>ACCESSORIES FOR MUTING</b>	
Muting arms, brackets and cables	---	See page 76
Muting Connection box <sup>C</sup>	---	SG-SRT-1 or SG-SRT-2
External muting lamps	---	LMS Series

#### NOTES

<sup>A</sup> Not possible with T or L muting arms mounted

<sup>B</sup> Use 6 brackets for light curtains with length ≥ 1200 mm

<sup>C</sup> When using EDM Relay Box or Muting connection boxes, connect EDM input, and be sure EDM function is active on the safety light curtain

## DIMENSIONS (mm)

### SG BODY REFLECTOR BASE - ACTIVE UNIT

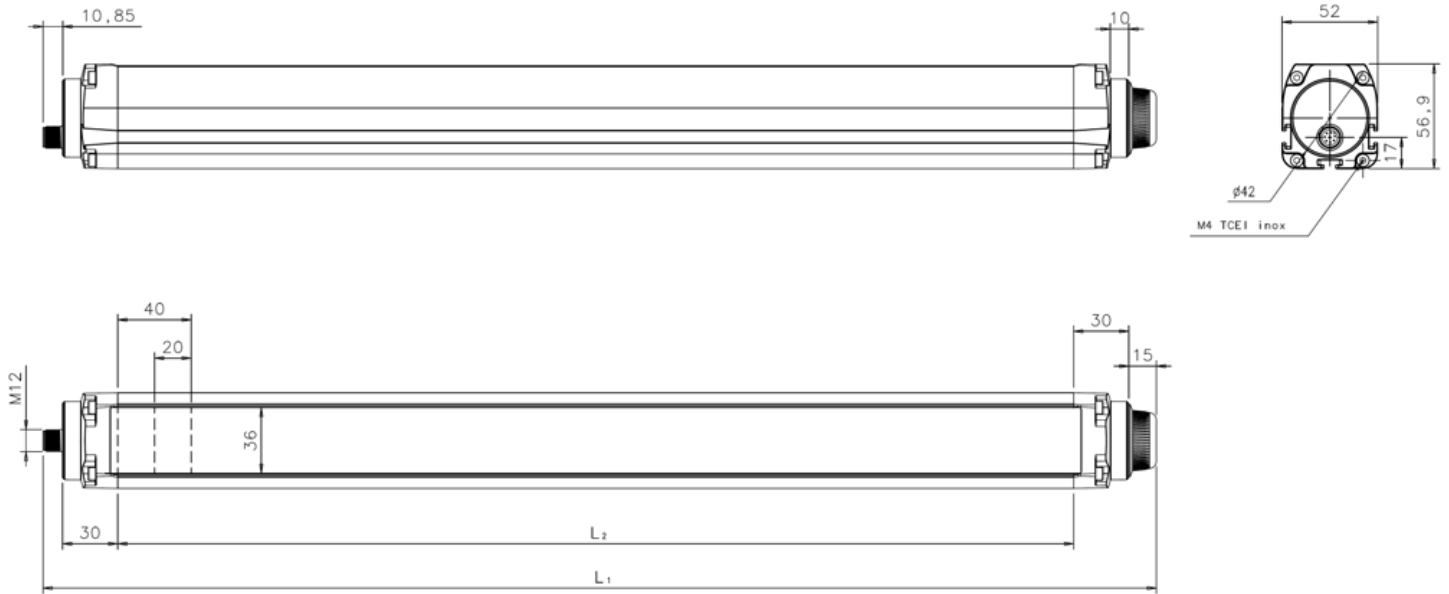

MODEL	L1 [mm]	L2 [mm]
SGx-RB2-050-00-E	606,35	520,5
SGx-RB3-080-00-E	906,35	820,5
SGx-RB4-090-00-E	1006,35	920,5
SGx-RB4-120-00-E	1306,35	1220,5

### SG BODY REFLECTOR MUTING - ACTIVE UNIT

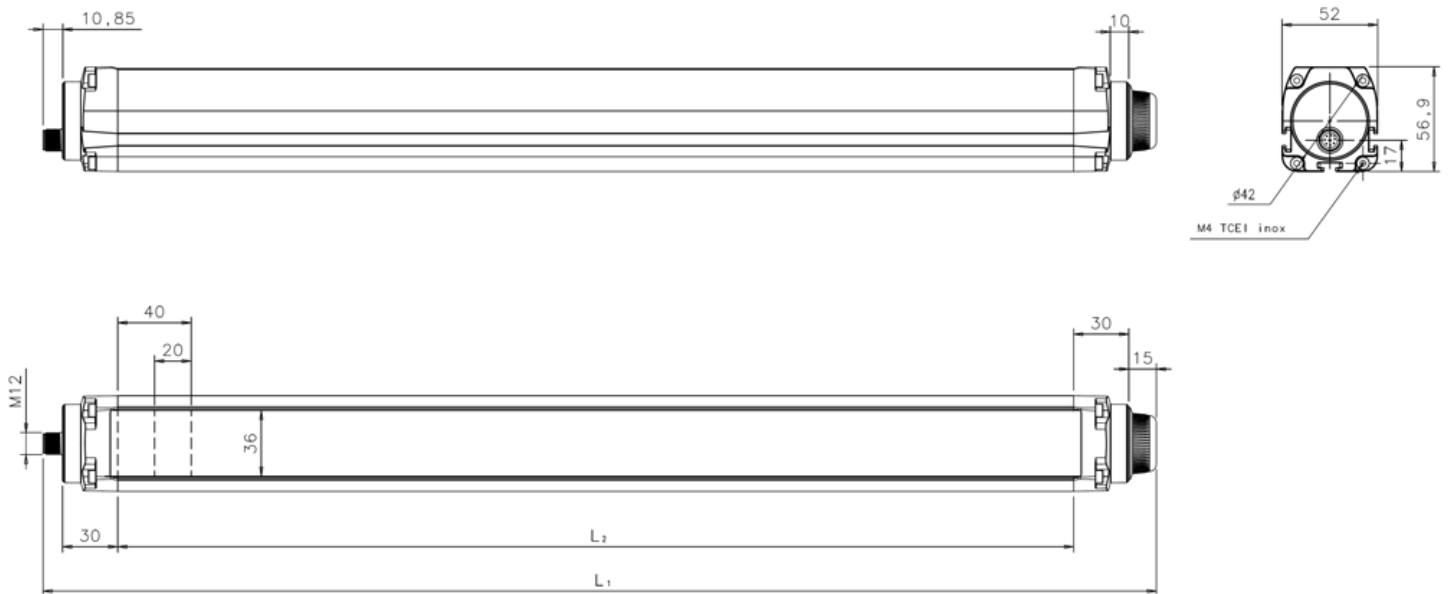

MODEL	L1 [mm]	L2 [mm]
SGx-RB2y-050-00-W	609,35	520,5
SGx-RB3y-080-00-W	909,35	820,5
SGx-RB4y-090-00-W	1009,35	920,5
SGx-RB4y-120-00-W	1309,35	1220,5

SG BODY REFLECTOR BASE - PASSIVE UNIT ■ SG BODY REFLECTOR MUTING - PASSIVE UNIT

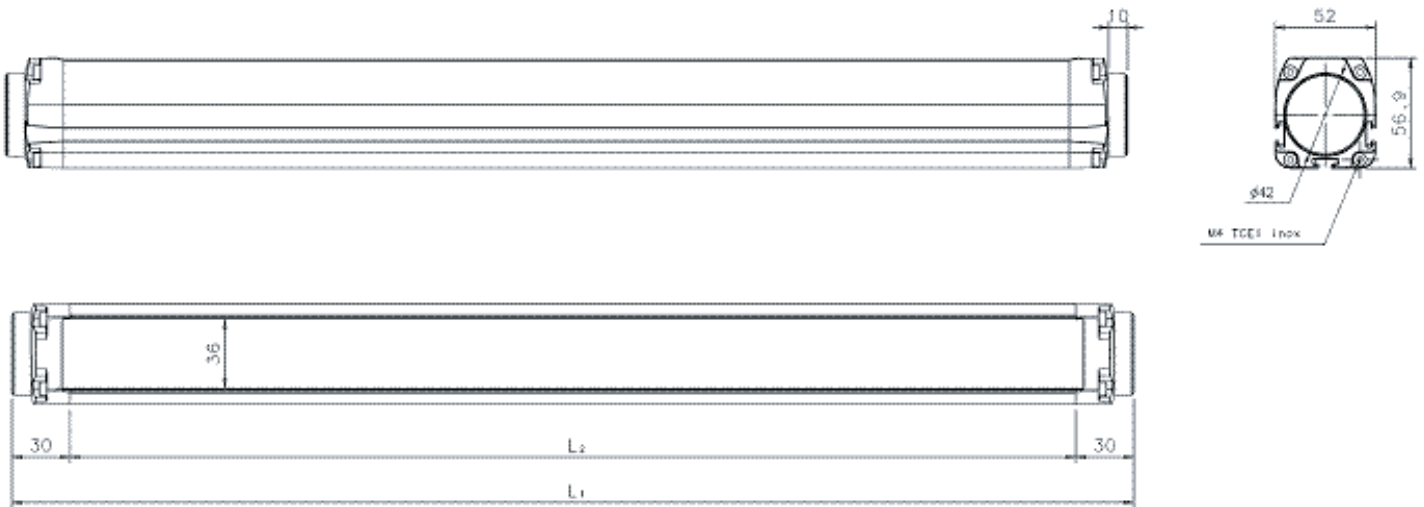

MODEL	L1 [mm]	L2 [mm]
SG4-RDB2	580,5	520,5
SG4-RDB2L	580,5	520,5
SG4-RDB2T	580,5	520,5
SG4-RDB3	880,5	820,5
SG4-RDB3L	880,5	820,5
SG4-RDB3T	880,5	820,5
SG4-RDB4-090	980,5	920,5
SG4-RDB4-120	1280,5	1220,5

SG BODY REFLECTOR BASE WITH T MUTING ARMS - ACTIVE SIDE

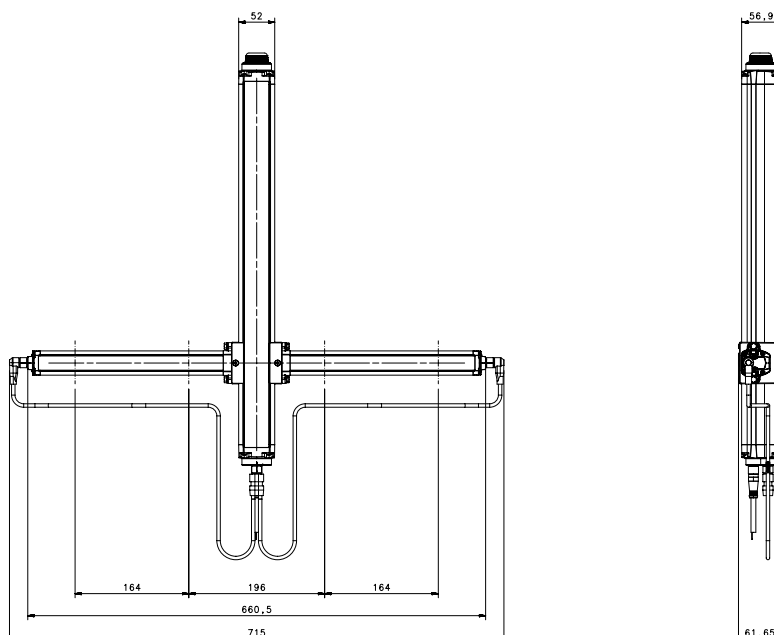



## SG BODY REFLECTOR MUTING WITH T MUTING ARMS - PASSIVE SIDE

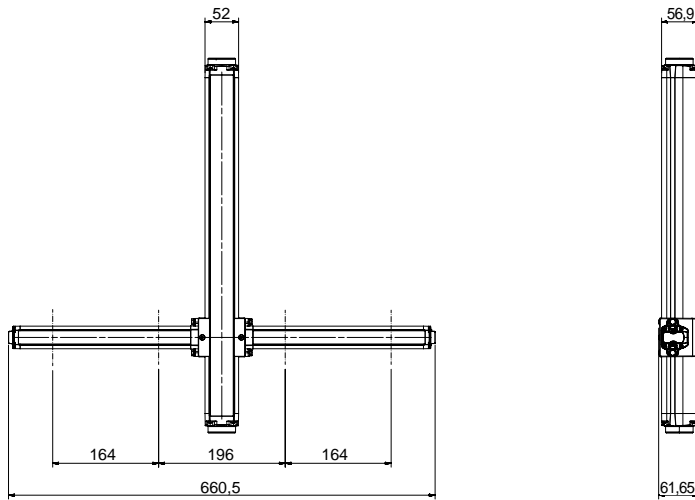

## SG BODY REFLECTOR MUTING WITH L MUTING ARM

ACTIVE SIDE

PASSIVE SIDE

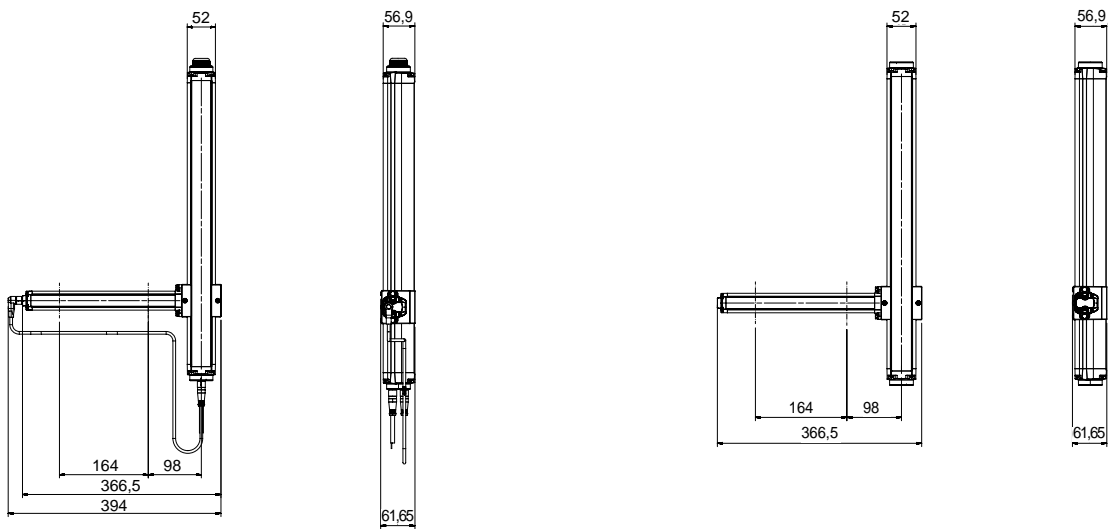

## INDICATORS

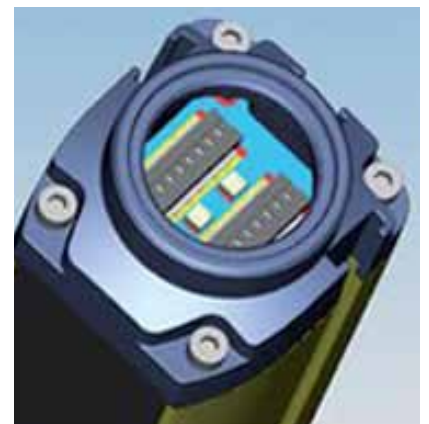
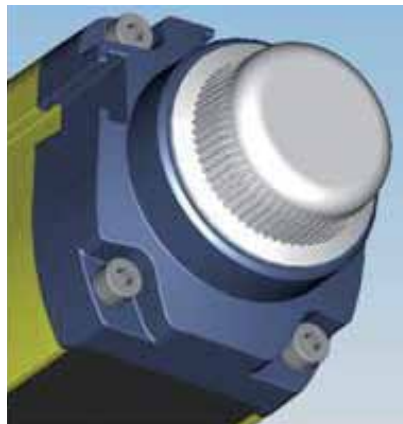
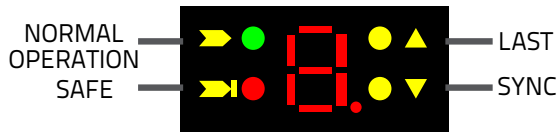

### AVAILABLE MODELS AND ORDER CODES

SG4 BODY REFLECTOR BASE [ SG4-RBX-XXX-OO-E ]		ORDER NUMBER	SG4 BODY REFLECTOR MUTING [ SG4-RBX-XXX-OO-W ]		ORDER NUMBER
ACTIVE SIDE	SG4-RB2-050-OO-E	957951000	LINEAR (WITHOUT MUTING ARMS)		
	SG4-RB3-080-OO-E	957951010	SG4-RB2-050-OO-W		957951030
	SG4-RB4-090-OO-E	957951190	SG4-RB3-080-OO-W		957951040
	SG4-RB4-120-OO-E	957951020	SG4-RB4-090-OO-W		957951180
	---	---	SG4-RB4-120-OO-W		957951050
	---	---	WITH T MUTING ARMS		
	---	---	SG4-RB2T-050-OO-W		957951080
	---	---	SG4-RB3T-080-OO-W		957951090
	---	---	WITH L MUTING ARMS		
	---	---	SG4-RB2L-050-OO-W		957951060
---	---	SG4-RB3L-080-OO-W		957951070	
SG4 BODY REFLECTOR BASE [ SG4-RDBX ] [ SG4-RDBX-XXX ]		ORDER CODE	SG4 BODY BIG MUTING [ SG4-RDBX ] [ SG4-RDBXL/T ]		ORDER CODE
PASSIVE SIDE	SG4-RDB2	957951100	LINEAR (WITHOUT MUTING ARMS)		
	SG4-RDB3	957951110	SG4-RDB2		957951100
	SG4-RDB4-090	957951170	SG4-RDB3		957951110
	SG4-RDB4-120	957951120	SG4-RDB4-090		957951170
	---	---	SG4-RDB4-120		957951120
	---	---	WITH T MUTING ARMS		
	---	---	SG4-RDB2T		957951150
	---	---	SG4-RDB3T		957951160
	---	---	WITH L MUTING ARMS		
	---	---	SG4-RDB2L		957951130
---	---	SG4-RDB3L		957951140	

#### IMPORTANT NOTES

- 1) Active and passive sides must be ordered separately
- 2) Brackets are not included in the SG4 BODY REFLECTOR packing and must be ordered separately (see accessories table)

### CABLE ORDER CODES

	ACTIVE UNIT (MAIN CONNECTOR)	LENGTH (m)	ORDER CODE
SG4 BODY REFLECTOR BASE [ SG4-RBx-xxx-OO-E ]	CS-A1-06-U-03	3	95ASE1220
	CS-A1-06-U-05	5	95ASE1230
	CS-A1-06-U-10	10	95ASE1240
	CS-A1-06-U-15	15	95ASE1250
	CS-A1-06-U-25	25	95ASE1260
	CS-A1-06-U-50	50	95A252710
SG4 BODY REFLECTOR MUTING [ SG4-RBx-xxx-OO-W ]	CS-A1-10-U-03	3	95A252720
	CS-A1-10-U-05	5	95A252730
	CS-A1-10-U-10	10	95A252740
	CS-A1-10-U-15	15	95A252750
	CS-A1-10-U-25	25	95A252760
	CS-A1-10-U-50	50	95A252770
	ACTIVE UNIT (SECONDARY CONNECTOR)	LENGTH (m)	ORDER CODE
SG4 BODY REFLECTOR MUTING [ SG4-RBx-xxx-OO-W ]	CS-A1-03-U-03	3	95ASE1170
	CS-A1-03-U-05	5	95ASE1180
	CS-A1-03-U-10	10	95ASE1190
	CS-A1-03-U-15	15	95ASE1200
	CS-A1-03-U-25	25	95ASE1210
	CS-A1-03-U-50	50	95A252700

#### NOTES

All cables have axial connectors

# SAFETY SENSORS

## SG2 MUTING SG4 EXTENDED



*State-of-the-art technology and versatility*  
*Easily adaptable to the machine structure*  
*Maximum application flexibility with*  
*configurable advanced functions*  
*Complete diagnostic and monitoring online*



- No dead zone
- Pigtail cable with M12 connector
- Cascade connection of up to 3 units
- Up to 20m operating range and 1800m protected height
- Compact dimensions (35 x 41 mm section)
- Anti-interference coding
- Integrated Muting function
- Floating Blanking, Fixed Blanking and Reduced Resolution
- Configurable with
  - Autoteaching
  - Pushbuttons for common configuration
  - Graphic User Interface for complete parametrisation
- Ethernet Interface for programming, monitoring and error logging



	FINGER	HAND	ARM	BODY
TYPE 2		▪		
TYPE 4	▪	▪		

### SG4-14-030-00-P

TYPE	
2	Type 2
4	Type 4

MONITORED HEIGHT	
030	300 mm
045	450 mm
...	
180	1800 mm

RESOLUTION	
14	Finger: 14 mm (only Type 4)
30	Hand: 30 mm

VERSION	
W	Basic Configuration Mode
P	Cascadable Advanced Configuration Mode

### CHARACTERISTICS

	SG2 MUTING [ SG2-30-xxx-00-W ]	SG4 EXTENDED [ SG4-xx-xxx-00-P ]
<b>GENERAL DATA</b>		
Type (EN61496-1-2)	2	4
PL (EN ISO 13849-1)	c	e
SIL (IEC 61508)	1	3
Resolution	30 mm	14, 30 mm
Protected height	300 ... 1800 mm (with 150 mm steps)	
Operating distance	0.2 ... 20 m	0.2 ... 7 m (14 mm resolution) 0.2 ... 20 m (30 mm resolution)
Dead Zone	No dead zone	
Cascade connection	---	Up to 3 units <sup>B</sup>
<b>ELECTRICAL DATA</b>		
Power supply (Vdd)	24 Vdc ± 20	
Outputs	2 PNP, with short circuit protection 2 PNP	
Output current	0.5 A max/each output	
Capacitive load	2.2 uF @ 24Vdc max	
Response time	13 ... 22 ms depending on model <sup>A</sup>	13 ... 33 ms depending on model <sup>A</sup>
Cables length (for power supply)	50 m max	
<b>MECHANICAL AND ENVIRONMENTAL DATA</b>		
Operating temperature	0 ... +50 °C	
Humidity	15 ... 95 % (no condensation)	
Mechanical protection	IP 65 (EN 60529)	
<b>FUNCTIONS</b>		
	Test input	
	Manual/Automatic Restart	
	External Device Monitoring (EDM)	
	---	Anti-interference coding
	Range reduction	
	T Muting/L Muting	
	---	Partial Muting
	---	Filter on muting signals
	Muting dependent Override	
	---	Floating Blanking
	---	Fixed Blanking
Max. Number of Blanking Areas	---	5
	---	Reduced Resolution

#### NOTES

<sup>A</sup> The response time depends on model; when a cascaded system is used, depends also on the number of units connected.  
For detailed informations refer to related Product Datasheet or Manual.

<sup>B</sup> The three units can be one "master" and two "slaves". The maximum "slaves" length can't exceed 1200 mm. The maximum number of beams of the overall system is 160 beams for 30 mm resolution, and 320 beams for 14 mm resolution.

#### IMPORTANT NOTES:

- 1) The use of any type of blanking is not compatible with the use of Muting and Muting dependent Override.
- 2) In order to use Muting or Blanking with SG4 EXTENDED, the correct pigtail cable must be used (see accessories table)

## CONNECTORS

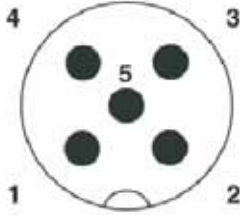
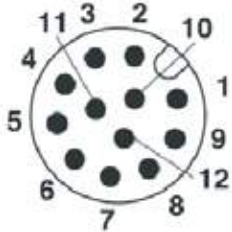
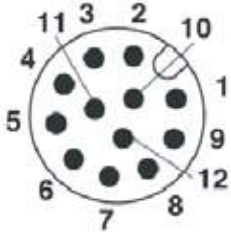
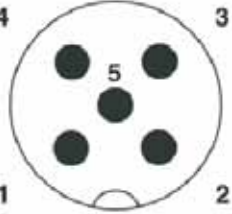
	SG2 MUTING [ SG2-30-XXX-00-W ]	SG4 EXTENDED [ SG4-XX-XXX-00-P ] CONFIGURATION FOR MUTING	SG4 EXTENDED [ SG4-XX-XXX-00-P ] CONFIGURATION FOR BLANKING
PIGTAIL CABLE FOR EMITTER*		CS-G1-50-B-002 (Order Number 95A252820)	
EMITTER		M12, 5 poles, male  1 = brown = 24Vdc; 2 = white = TEST; 3 = blue = 0V; 4 = black = EARTH; 5 = grey = RANGE REDUCTION.	
			
PIGTAIL CABLE FOR RECEIVER <sup>A</sup>	CS -R1-75-B-002 (Order Number 95A252810)		CS -G1-70-B-002 (Order Number 95A252830)
RECEIVER MAIN CONNECTOR	M12, 12 poles, male  1 = brown = 24Vdc 2 = blue = 0V 3 = white = RESET/RESTART/ALIGN 4 = green = OVERRIDE1 5 = pink = OSSD2 6 = yellow = EDM 7 = black = MUTING DISABLE 8 = grey = OSSD1 9 = red = OVERRIDE2 10 = violet = MUTING LAMP 11 = grey-pink = OVERRIDE STATUS 12 = red-blue = EARTH		M12, 12 poles, male  1 = brown = 24Vdc 2 = blue = 0V 3 = white = RESET/RESTART/ALIGN 4 = green = TEACH IN 5 = pink = OSSD2 6 = yellow = EDM 8 = grey = OSSD1 9 = red = TOLERANCE 10 = violet = LAMP 12 = red-blue = EARTH
			
RECEIVER SECONDARY CONNECTOR	M12, 5 poles, male  1 = brown = 24Vdc 2 = white = MUTING2 3 = blue = 0V 4 = black = MUTING1		---
			

### <sup>A</sup> IMPORTANT NOTES

- 1) The light curtain is sold without pigtail cables: they must be ordered separately for Transmitter and Receiver.
- 2) In case of SG4 EXTENDED, the choice of the Receiver pigtail determines if it will work in Muting configuration or in Blanking configuration.
- 3) In case the SG4 EXTENDED will be installed together with the programming and monitoring interface (DONGLE), the pigtail cable for Receiver isn't needed.  
See accessories table for more informations about DONGLE

### ACCESSORIES

	SG2 MUTING [ SG2-30-XXX-00-W ]	SG4 EXTENDED [ SG4-XX-XXX-00-P ]
		<b>BRACKETS</b>
Standard angled brackets (included)		ST-KSTD
Antivibration support (4 pcs/6 pcs) <sup>A</sup>		ST-K4AV ST-K6AV
Plastic brackets (4 pcs/6 pcs) <sup>A</sup>		ST-KP4MP ST-KP6MP
Orientable brackets (4 pcs/6 pcs) <sup>A</sup>		ST-K4OR ST-K6OR
		<b>STANDS</b>
Protective Stands		SG-PSB series
Stand Plate for SG-PSB		SG-P
Protective Stands Mounting Brackets (4 pcs/6 pcs) <sup>A</sup>		ST-PS4-SG-SE ST-PS6-SG-SE
Floor columns		SE-S Series
		<b>MIRRORS</b>
Deviating Mirrors		SG-DM Series
Deviating Mirrors mounting kit for SG-PSB		ST-PS-DM
Mirror Mounting Bracket		ST-DM
		<b>SAFETY UNITS</b>
Safety Unit		SE-SR2
EDM Relay Box <sup>B</sup>		CS ME-03VU24-Y14
Safety control unit for single beams and SLC		SG-BWS-T4-MT
		<b>ALIGNMENT TOOL</b>
LASER Pointer		SG-LP
		<b>COMMUNICATION TOOLS</b>
Ethernet Adaptor (Dongle)	---	SG4-DONGLE
Ethernet Cable	---	CAB-ETH-M01
		<b>CONFIGURATION SOFTWARE</b>
Monitoring and Programming Software <sup>C</sup>		SG EXTENDED Graphic User Interface <sup>C</sup>
		<b>MUTING ACCESSORIES</b>
External muting lamps		LMS series
Muting arms, brackets and cables		See page 76

#### NOTES

<sup>A</sup> Use 6 brackets for light curtains with length  $\geq 1200$  mm

<sup>B</sup> When using EDM Relay Box, connect EDM input, and be sure EDM function is active on the safety light curtain

<sup>C</sup> SG EXTENDED GUI is available from DATALOGIC website

### DIMENSIONS (mm)

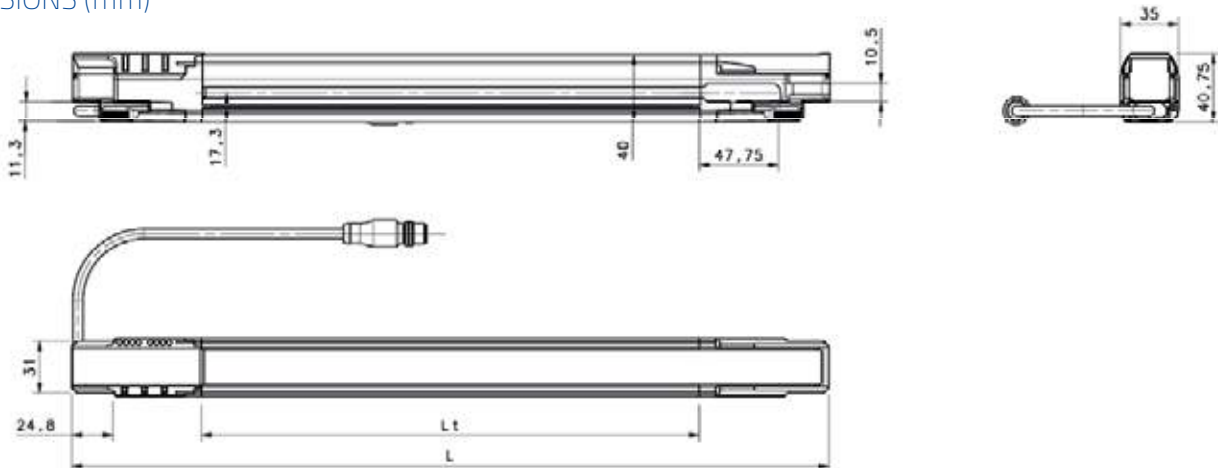

SG2 MUTING	SG4 EXTENDED	Lt (mm)	L (mm)
SG2-xx-030-00-W	SG4-xx-030-00-P	150	306,3
SG2-xx-045-00-W	SG4-xx-045-00-P	300	456,3
SG2-xx-060-00-W	SG4-xx-060-00-P	450	606,3
SG2-xx-075-00-W	SG4-xx-075-00-P	600	756,3
SG2-xx-090-00-W	SG4-xx-090-00-P	750	906,3
SG2-xx-105-00-W	SG4-xx-105-00-P	900	1056,3
SG2-xx-120-00-W	SG4-xx-120-00-P	1050	1206,3
SG2-xx-135-00-W	SG4-xx-135-00-P	1200	1356,3
SG2-xx-150-00-W	SG4-xx-150-00-P	1350	1506,3
SG2-xx-165-00-W	SG4-xx-165-00-P	1500	1656,3
SG2-xx-180-00-W	SG4-xx-180-00-P	1650	1806,3

# SAFETY SENSORS | SG2 MUTING | SG4 EXTENDED

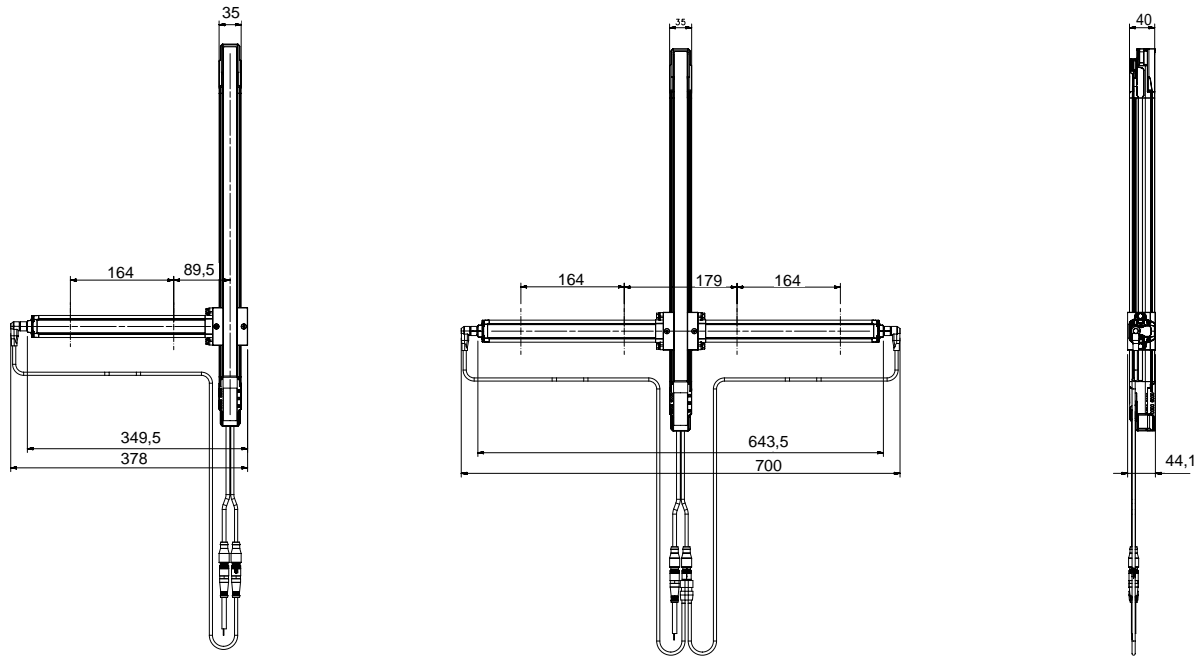

## INDICATORS

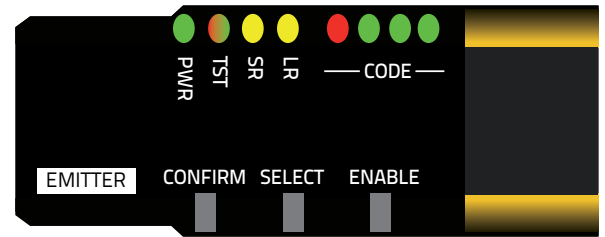
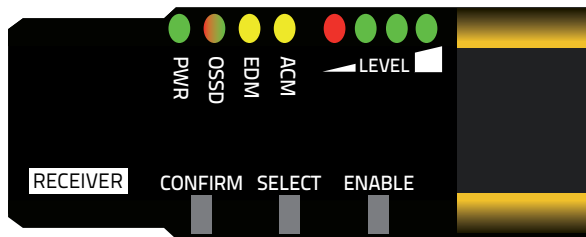

## AVAILABLE MODELS AND ORDER CODES

	SG2 MUTING [ SG2-30-XXX-00-W ]	ORDER NUMBER	SG4 EXTENDED [ SG4-XX-XXX-00-P ]	ORDER NUMBER
FINGER PROTECTION	---		SG4-14-030-00-P	957901240
	---		SG4-14-045-00-P	957901250
	---		SG4-14-060-00-P	957901260
	---		SG4-14-075-00-P	957901270
	---		SG4-14-090-00-P	957901280
	---		SG4-14-105-00-P	957901290
	---		SG4-14-120-00-P	957901300
	---		SG4-14-135-00-P	957901310
	---		SG4-14-150-00-P	957901320
HAND PROTECTION	---		SG4-14-165-00-P	957901330
	---		SG4-14-180-00-P	957901340
	SG2-30-030-00-W	957801700	SG4-30-030-00-P	957901350
	SG2-30-045-00-W	957801710	SG4-30-045-00-P	957901360
	SG2-30-060-00-W	957801720	SG4-30-060-00-P	957901370
	SG2-30-075-00-W	957801730	SG4-30-075-00-P	957901380
	SG2-30-090-00-W	957801740	SG4-30-090-00-P	957901390
	SG2-30-105-00-W	957801750	SG4-30-105-00-P	957901400
	SG2-30-120-00-W	957801760	SG4-30-120-00-P	957901410
	SG2-30-135-00-W	957801770	SG4-30-135-00-P	957901420
SG2-30-150-00-W	957801780	SG4-30-150-00-P	957901430	
SG2-30-165-00-W	957801790	SG4-30-165-00-P	957901440	
SG2-30-180-00-W	957801800	SG4-30-180-00-P	957901450	

### NOTES

<sup>A</sup> The light curtain is sold without pigtail cables: they must be ordered separately for Transmitter and Receiver. In case of SG4 EXTENDED, the choice of the Receiver pigtail determines in Muting configuration or Blanking configuration. For cascade configurations, other cables are available to connect the cascaded units: refer to the accessories table.

### CABLE ORDER CODES

PIGTAIL CABLES/INTERFACE SELECTION TABLE				
		PIGTAIL CABLE/INTERFACE	LENGTH (m)	ORDER CODE
SG2 MUTING [ SG2-30-xxx-00-W ]	TRANSMITTER	CS-G1-50-B-002	0.2	95A252820
	RECEIVER	CS-R1-75-B-002	0.2	95A252810
	TRANSMITTER	CS-G1-50-B-002	0.2	95A252820
SG4 EXTENDED [ SG4-xx-xxx-00-P ]	RECEIVER	BLANKING CONFIGURATION		
		CS-G1-70-B-002	0.2	95A252830
		MUTING CONFIGURATION		
		CS-R1-75-B-002	0.2	95A252810
		DONGLE		
		SG4-DONGLE	---	95ASE2080

#### NOTES

- 1) The light curtain is sold without pigtail cables: they must be ordered separately for Transmitter and Receiver.
- 2) For SG4 EXTENDED, the pigtail cable used determines if the light curtain will work in Muting configuration or in Blanking configuration. If, in place of the pigtail cable, the Dongle is used for receiver, the light curtain can work in both configurations. When muting and blanking are not needed, Dongle or pigtail cable CS-G1-70-B-002 are suggested
- 3) If SG4 EXTENDED receiver is connected to the programming and monitoring interface (DONGLE), the pigtail cable for Receiver isn't needed.
- 4) In order to install SG4 EXTENDED or SG2 MUTING in place of SE series safety light curtains, without changing any wiring, it can be used the cable CS-G1-60-B-002 (order n. 95A252910) for receiver. All functions of SE will be available, except Override.

CABLES SELECTION TABLE				
	TRANSMITTER/RECEIVER SECONDARY CONNECTOR	LENGTH (m)	ORDER CODE	
SG2 MUTING [ SG2-30-xxx-00-W ]  SG4 EXTENDED [ SG4-xx-xxx-00-P ]	CS-A1-03-U-03	3	95ASE1170	
	CS-A1-03-U-05	5	95ASE1180	
	CS-A1-03-U-10	10	95ASE1190	
	CS-A1-03-U-15	15	95ASE1200	
	CS-A1-03-U-25	25	95ASE1210	
	CS-A1-03-U-50	50	95A252700	
	RECEIVER MAIN CONNECTOR		LENGTH (m)	ORDER CODE
	CS-A1-10-U-03	3	95A252720	
	CS-A1-10-U-05	5	95A252730	
	CS-A1-10-U-10	10	95A252740	
	CS-A1-10-U-15	15	95A252750	
	CS-A1-10-U-25	25	95A252760	
	CS-A1-10-U-50	50	95A252770	

CASCADE CABLES		
MODEL	LENGTH (m)	ORDER CODE
CS-F1-80-B-01	1 m	95A252840
CS-F1-80-B-005	0.5 m	95A252850
CS-F1-80-B-0005	0.05 m	95A252860

ETHERNET CABLES		
MODEL	LENGTH (m)	ORDER CODE
CAB-ETH-M01 M12-IP67	1	93A051346
CAB-ETH-M03 M12-IP67	3	93A051347
CAB-ETH-M05 M12-IP67	5	93A051348



# SAFETY SENSORS

# SINGLE BEAM SAFETY SENSORS SAFETY CONTROL UNITS

*Installation Flexibility*

*Long distance*

*Low temperature with defogging function*

*4 safety areas controlled with one unit*

*Double muting*



**SENSORS:**

- Emitter-receiver photocells with test input
- Type 2 and Type 4 models
- Plastic tubular and MAXI formats
- Up to 50m operating distance
- Class 1 red laser emission models up to 40
- Standard M12 connectors

**CONTROL UNITS:**

- Integrated control of 4 single beams and 2 light curtains
- Simple DIP Switch configuration
- Muting functions can be assigned to light curtains or single beams



## S5-5-G8-62-SG-ST2

EMITTER/RECEIVER		TYPE	
G8-62	Emitter	2	Type 2
F8-92	Receiver	4	Type 4

## SL5-5-G-82-SG-ST4

EMITTER/RECEIVER	
G-82	Emitter
F-92	Receiver

## S300-PR-5-G00-EX-M-SG-ST2

EMITTER/RECEIVER		DEFOGGING FUNCTION		TYPE	
G00-EX	Emitter	...	Standard	2	Type 2
F00-OC	Receiver	M	Defogging	4	Type 4

### CHARACTERISTICS

	S5	SL5	S300
<b>GENERAL DATA</b>			
Format	M18 Tubular	M18 Tubular	Rectangular
Light Emission	Infrared LED 880 nm	Class 1 Red laser (650 nm)	Infrared LED 880 nm
Type (EN61496-1)	2/4 depending on model	4	2/4 depending on model
Effective Aperture Angle (EN61496-2)		-/+ 2.5° for Type 4 models -/+ 5° for Type 2 models	
Operating distance	0 ... 8 m	0 ... 40 m	0 ... 50 m (S300...ST2) 9 ... 40 m (S300...ST4)
<b>ELECTRICAL DATA</b>			
Power supply (Vdc)	24 Vdc ± 15%		
Outputs	PNP (short circuit protection)		
Output current	100 mA max.		
Response time	1 ms max.		
<b>MECHANICAL AND ENVIRONMENTAL DATA</b>			
Operating temperature	-25 ... 55°C	-10 ... 50 °C	-40 ... 55 °C
Mechanical protection (EN 60529)	IP 67		

	SG-BWS-T4	SG-BWS-T4-MT
<b>GENERAL DATA</b>		
PL (EN ISO 13849-1)	e	
SIL (IEC 61508)	3	
<b>ELECTRICAL DATA</b>		
Power supply	24 Vdc -15/+10%	
<b>Inputs</b>		
PNP Outputs from S5/SL5/S300	4	4
OSSDs couples from SLC	---	2
Muting inputs	---	4
Test, Reset, Override, EDM, Muting enable, Auto/Man Selector	3	9
<b>Outputs</b>		
Safety outputs	2 PNP	2 NO
Muting lamps	---	2
Test outputs	4	4
Response time <sup>A</sup>	29 ms	39 ms
<b>MECHANICAL AND ENVIRONMENTAL DATA</b>		
Operating temperature	0 ... +55°C	
Humidity	15 ... 95 % (no condensation)	
Mechanical protection	IP20	
<b>FUNCTIONS <sup>B</sup></b>		
	Automatic/Manual reset	
	External Device Monitoring	
	---	L/T Muting
	---	Double muting
	---	Muting Enable
	---	Muting timeout
	---	Override
<b>COMPATIBILITY</b>		
Single beam photocells	S5/SL5/S300	
Safety light curtains	---	All DATALOGIC SLC

#### NOTES

<sup>A</sup> includes response time of photocells

<sup>B</sup> Functions setting is done through DIP switches in SG-BWS-T4-MT and through wiring in SG-BWS-T4

### CONNECTORS

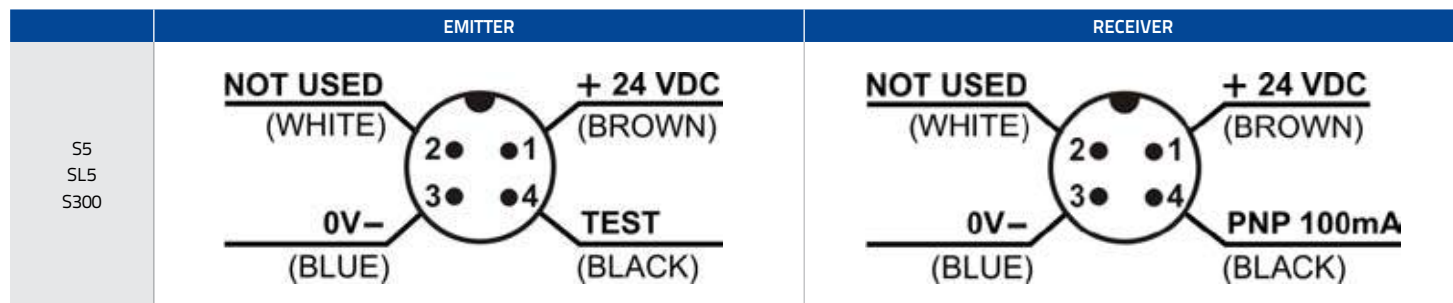

### ACCESSORIES

MODEL	DESCRIPTION	ORDER NUMBER
SP-40	Fixed support for tubular M18 sensors	95ACC1370
SWING-18	Adjustable support for plastic tubular M18 sensors	895000006
MICRO-18	Support with micrometric regulation for tubular M18 sensors	95ACC1380
ST-5099	S300 Fixed bracket	95ACC2830
ST-5100	S300 Fixed bracket	95ACC2840
DataVS-MK-01	S300 Mounting kit	95A901380

### DIMENSIONS (mm)

#### S5

S5-5-F8-92-SG-ST2

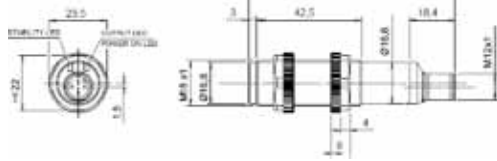

S5-5-G8-62-SG-ST2

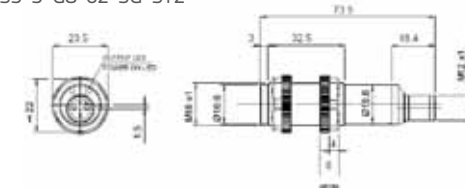

S5-5-F8-92-SG-ST4

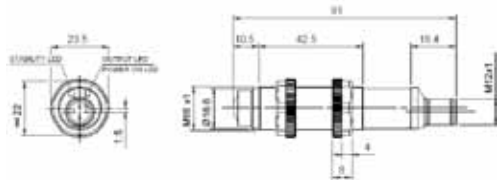

S5-5-G8-62-SG-ST4

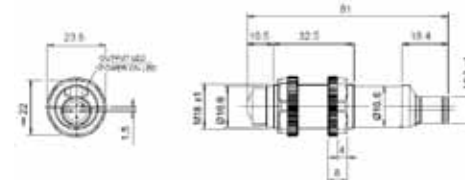

#### SL5

SL5-5-F-92-SG-ST4

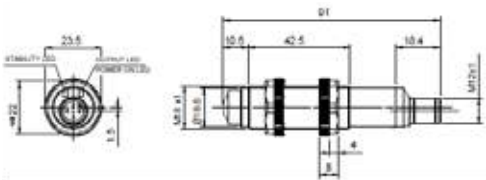

SL5-5-G-82-SG-ST4

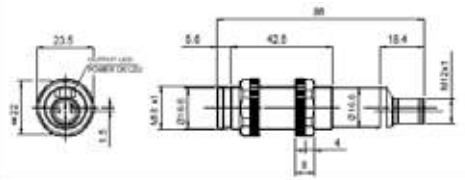

#### S300

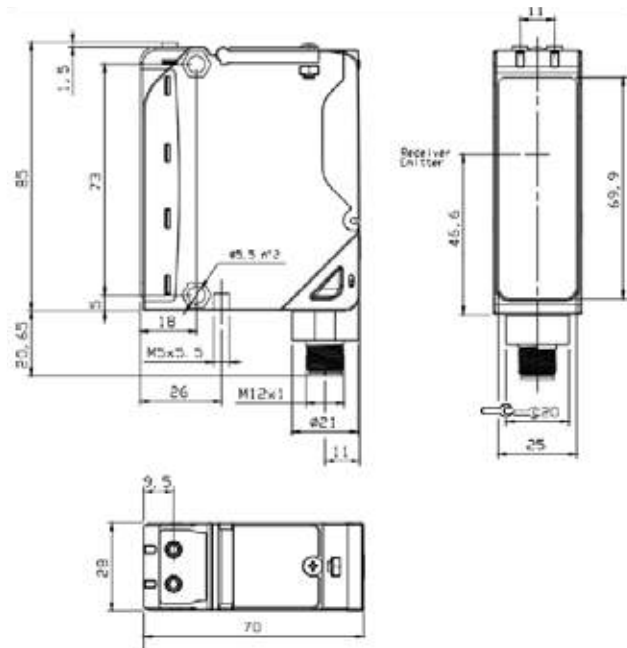

### ORDER CODES

SAFETY CONTROL UNITS		
MODEL	DESCRIPTION	ORDER NUMBER
SG-BWS-T4	Safety control unit pl=e auto/man edm	957051000
SG-BWS-T4-MT	Safety control unit pl=e double muting	957051010

SINGLE BEAM SAFETY SENSORS				
	TYPE	MODEL	EMITTER/RECEIVER	ORDER NUMBER
S5	2	S5-5-G8-62-SG-ST2	Emitter	952051870
		S5-5-F8-92-SG-ST2	Receiver	952051890
	4	S5-5-G8-62-SG-ST4	Emitter	952051910
		S5-5-F8-92-SG-ST4	Receiver	952051930
SL5	4	SL5-5-G-82-SG-ST4	Emitter	952501160
		SL5-5-F-92-SG-ST4	Receiver	952501170
S300	2	S300-PR-5-G00-EX-SG-ST2	Emitter	951451320
		S300-PR-5-F00-OC-SG-ST2	Receiver	951451340
	4	S300-PR-5-G00-EX-SG-ST4	Emitter	951451360
		S300-PR-5-F00-OC-SG-ST4	Receiver	951451380
S300 DEFOGGING	2	S300-PR-5-G00-EX-M-SG-ST2	Emitter	951451330
		S300-PR-5-F00-OC-M-SG-ST2	Receiver	951451350
	4	S300-PR-5-F00-OC-M-SG-ST4	Emitter	951451390
		S300-PR-5-G00-EX-M-SG-ST4	Receiver	951451370

#### NOTES

1) The photocells listed above are certified and must be used only with safety control units SG-BWS-T4 and SG-BWS-T4-MT.  
Neither technical and functioning compatibility nor certifications are guaranteed if they are used with other brand control units or old/obsolete DATALOGIC control units.

### CABLE ORDER CODES

MODEL	DESCRIPTION	ORDER NUMBER
CS -A1-02-U-03	4-pole M12 cable (axial) 3 m	95ASE 1120
CS -A1-02-U-05	4-pole M12 cable (axial) 5 m	95ASE 1130
CS -A1-02-U-10	4-pole M12 cable (axial) 10 m	95ASE 1140
CS -A1-02-U-15	4-pole M12 cable (axial) 15 m	95ASE 1150
CS -A1-02-U-25	4-pole M12 cable (axial) 25 m	95ASE 1160



# ACCESSORIES



# ACCESSORIES





# ACCESSORIES

## BRACKETS

### Metal angled brackets

MODEL	DESCRIPTION	ORDER NUMBER
ST-KSTD	Fixing brackets (4 pcs kit)	95ACC1670

#### COMPATIBILITY

SG2 BASE, SG4 BASE  
 SG2 EXTENDED, SG4 EXTENDED  
 SG2/4 COMPACT BODY  
 SG2 MUTING  
 SG2/4 BODY BIG,  
 SG4 BODY REFLECTOR,  
 SG4 LONG RANGE BASE.

#### NOTES

They can be used in combination with orientable (ST-K4OR/K6OR) or antivibration (ST-K4AV/K6AV) supports.

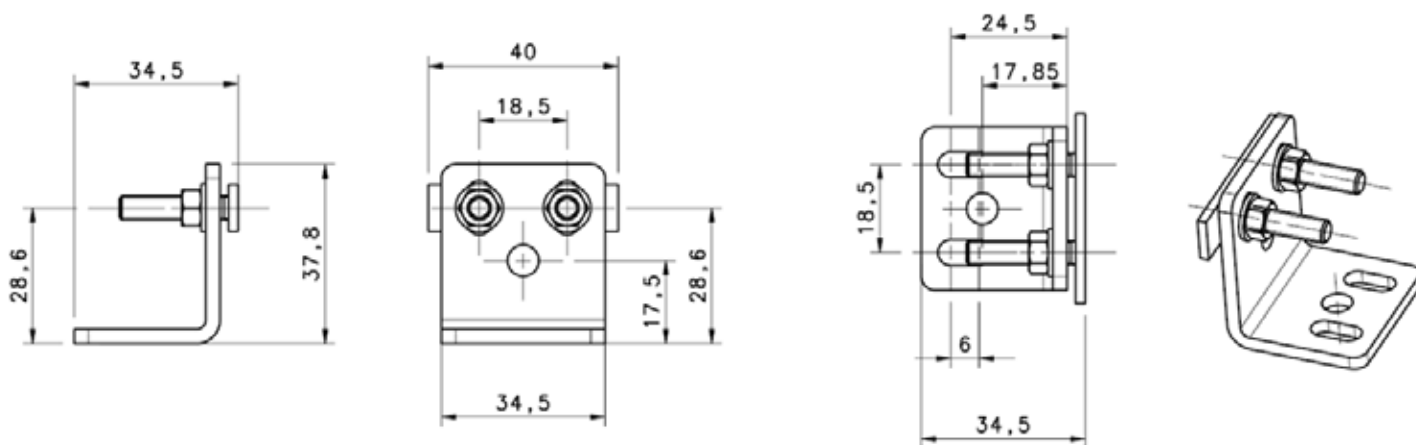

MODEL	DESCRIPTION	ORDER NUMBER
ST-K4STD-SG BODY BIG	Fixing brackets (4 pcs kit) for SG BODY BIG	95ASE1950

#### COMPATIBILITY

SG BODY BIG

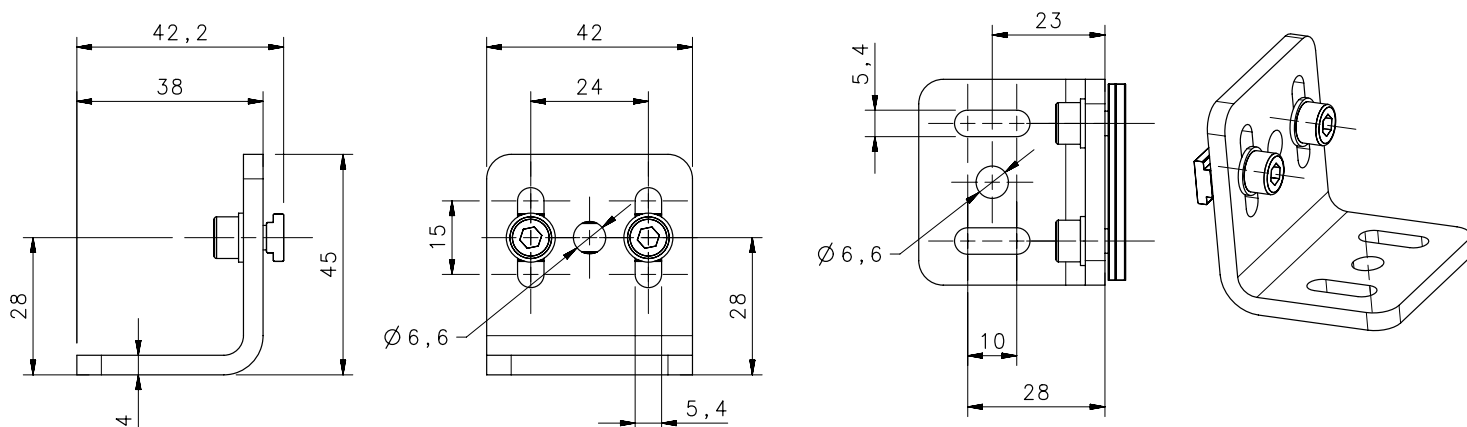

# ACCESSORIES | BRACKETS

MODEL	DESCRIPTION	ORDER NUMBER
ST-K4OR	Orientable supports (4 pcs kit)	95ACC1680
ST-K6OR	Orientable supports (6 pcs kit)	95ACC1690
<b>COMPATIBILITY</b>		
	SG2 BASE, SG4 BASE SG2 EXTENDED, SG4 EXTENDED SG2/4 COMPACT BODY SG2 MUTING SG2/4 BODY BIG, SG4 BODY REFLECTOR, SG4 LONG RANGE BASE.	

## NOTES

They can be used together with metal angled fixing brackets (ST-KSTD) or plastic angled mounting brackets (ST-KP4MP/KP6MP), also in combination with antivibration supports (ST-K4AV/K6AV)

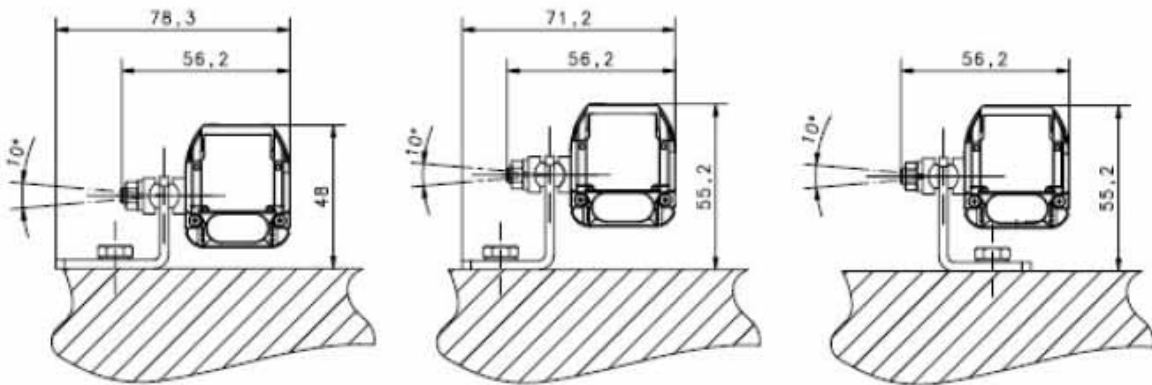

*Angled mounting bracket*

NOTE: the dimensions are related to SG4 EXTENDED. For other models of light curtains, refer to their manual.

MODEL	DESCRIPTION	ORDER NUMBER
ST-K4AV	Anti-vibration supports (4 pcs kit)	95ACC1700
ST-K6AV	Anti-vibration supports (6 pcs kit)	95ACC1710
<b>COMPATIBILITY</b>		
	SG2 BASE, SG4 BASE SG2 EXTENDED, SG4 EXTENDED SG2/4 COMPACT BODY SG2 MUTING SG2/4 BODY BIG, SG4 BODY REFLECTOR, SG4 LONG RANGE BASE.	

## NOTES

Anti-vibration supports to be used together with metal angled mounting brackets (ST-KSTD, ST-K4STD-SG BODY BIG) or plastic angled mounting brackets (ST-KP4MP/KP6MP), also in combination with orientable supports (ST-K4OR/K6OR).

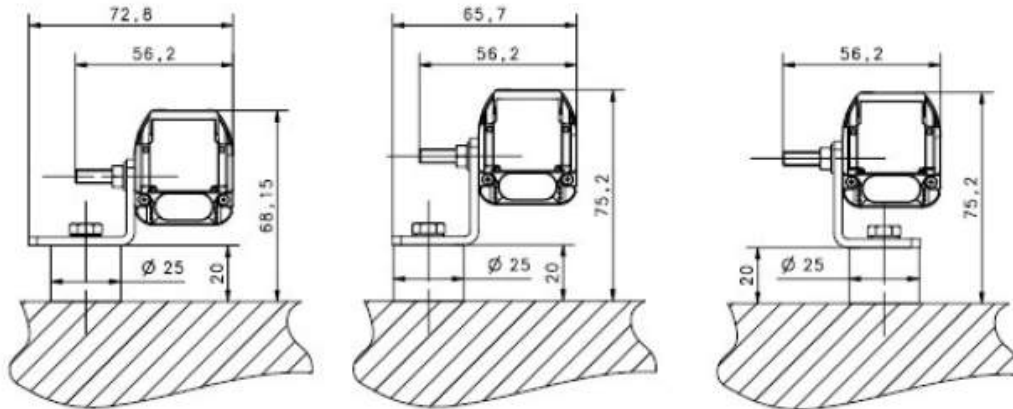

Angled mounting bracket + Anti-vibration support

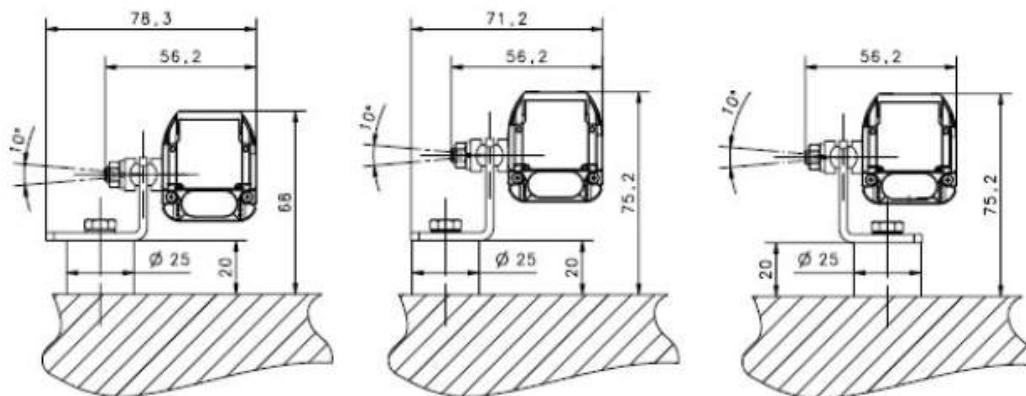

Angled mounting bracket + Orientable support + Anti-vibration support

NOTE: the dimensions (mm) are related to SG4 EXTENDED. For other models of light curtains, refer to their manual.

## Plastic angled brackets

MODEL	DESCRIPTION	ORDER NUMBER
ST-KP4MP	Fixing brackets (4 pcs kit)	95ASE1100
ST-KP6MP	Fixing brackets (6 pcs kit)	95ASE1110

### COMPATIBILITY

SG2 BASE, SG4 BASE  
 SG2 EXTENDED, SG4 EXTENDED  
 SG2/4 BODY COMPACT  
 SG2 MUTING  
 SG2/4 BODY BIG  
 SG4 BODY REFLECTOR  
 SG4 LONG RANGE BASE.

### NOTES

They can be used in combination with orientable (ST-K4OR/K6OR) or antivibration (ST-K4AV/K6AV) supports.

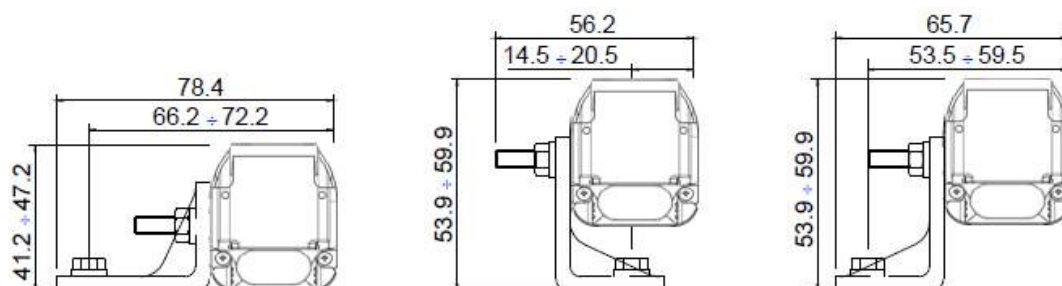

NOTE: the dimensions (mm) are related to SG4 EXTENDED. For other models of light curtains, refer to their manual.

## Cascade brackets

MODEL	DESCRIPTION	ORDER NUMBER
ST-KCASCADE-SG EXTENDED	Connection Bracket for SG4 EXTENDED Cascade	95ASE2110
COMPATIBILITY		
SG4 EXTENDED		

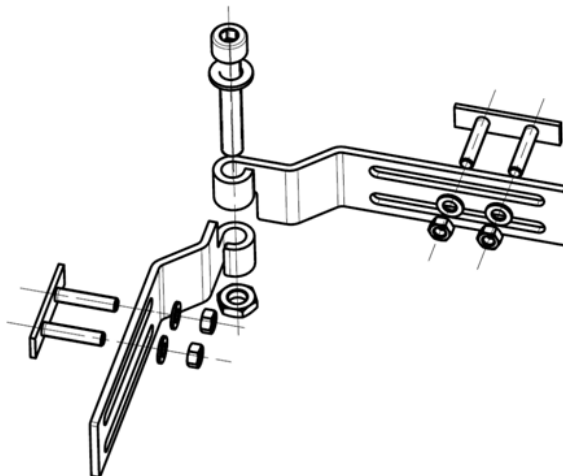

## Rear brackets

MODEL	DESCRIPTION	ORDER NUMBER
ST-K4REAR-SG BODY BIG	Metal rear bracket mounting kit (4 brackets)	95ASE1970
COMPATIBILITY		
SG BODY BIG SG BODY REFLECTOR SG4 LONG RANGE BASE.		

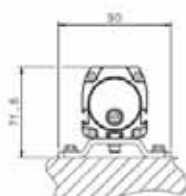
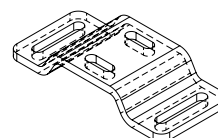
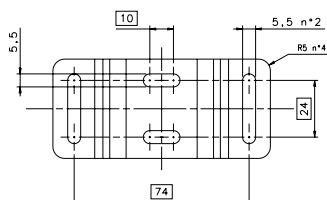
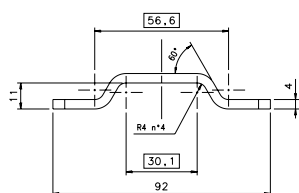

## Rotative brackets

MODEL	DESCRIPTION	ORDER NUMBER
ST-K4ROT-SG BODY BIG	Metal top-bottom rotative fixing bracket mounting kit (4 brackets)	95ASE1960
COMPATIBILITY		
SG BODY BIG SG BODY REFLECTOR SG4 LONG RANGE BASE.		

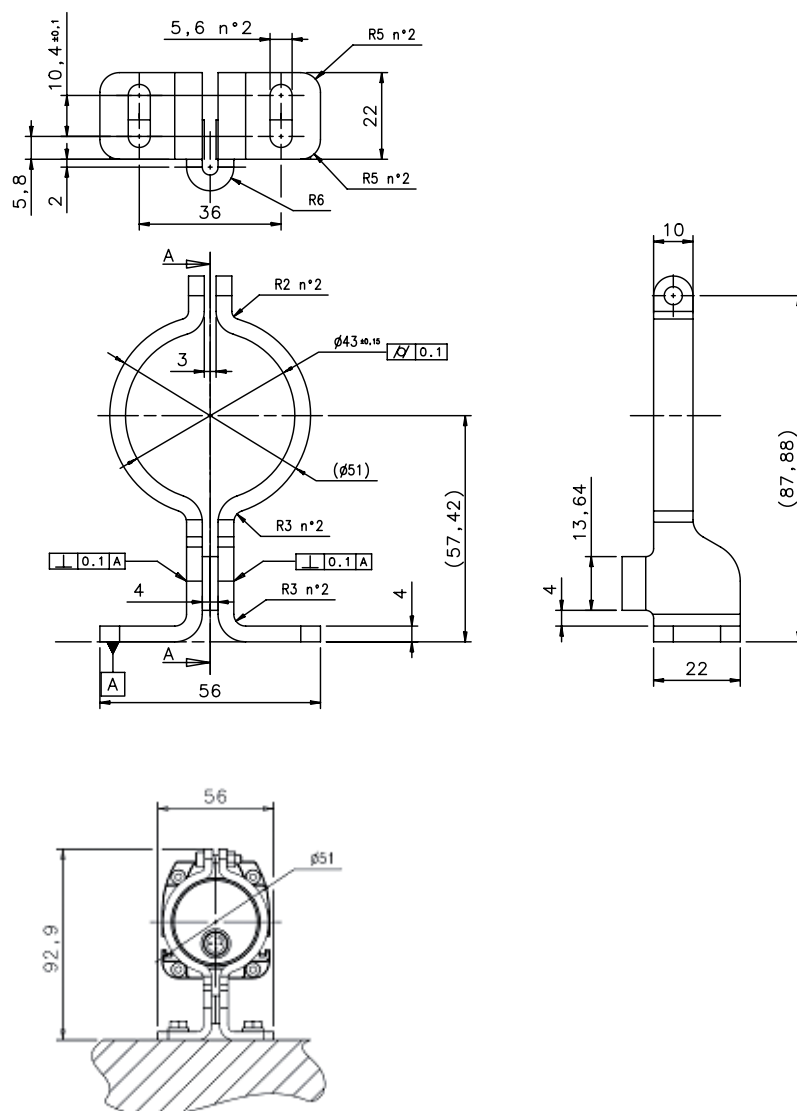

# ACCESSORIES | BRACKETS

MODEL	DESCRIPTION	ORDER NUMBER
ST-K4ROT-SG BODY COMPACT	Metal top-bottom rotative bracket mounting kit (4 brackets)	95ASE2040
COMPATIBILITY		
SG BODY COMPACT		

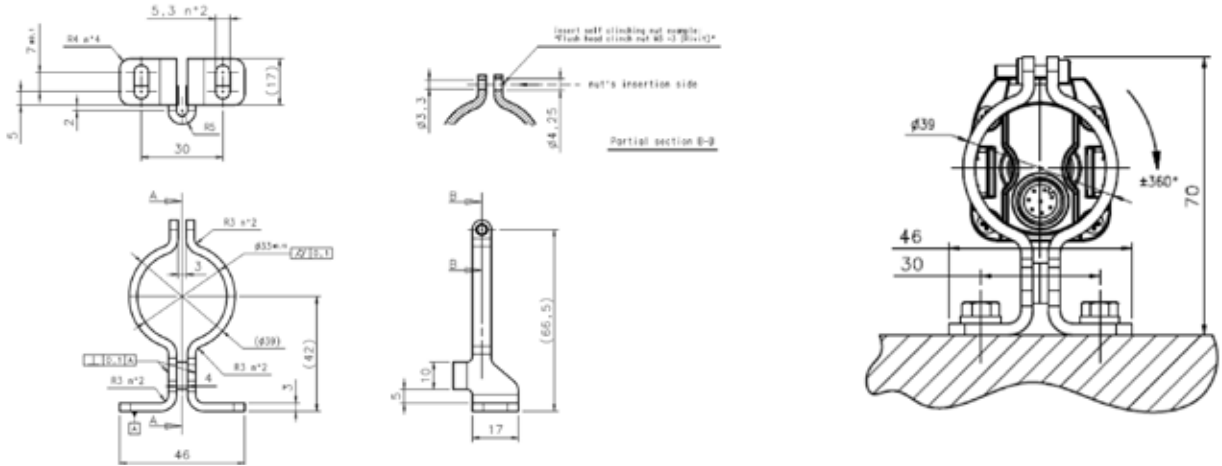

MODEL	DESCRIPTION	ORDER NUMBER
ST-K4ROT	Metal top-bottom rotating brackets kit (4 brackets)	95ASE1280
COMPATIBILITY		
SG2 BASE SG4 BASE SG2 EXTENDED		

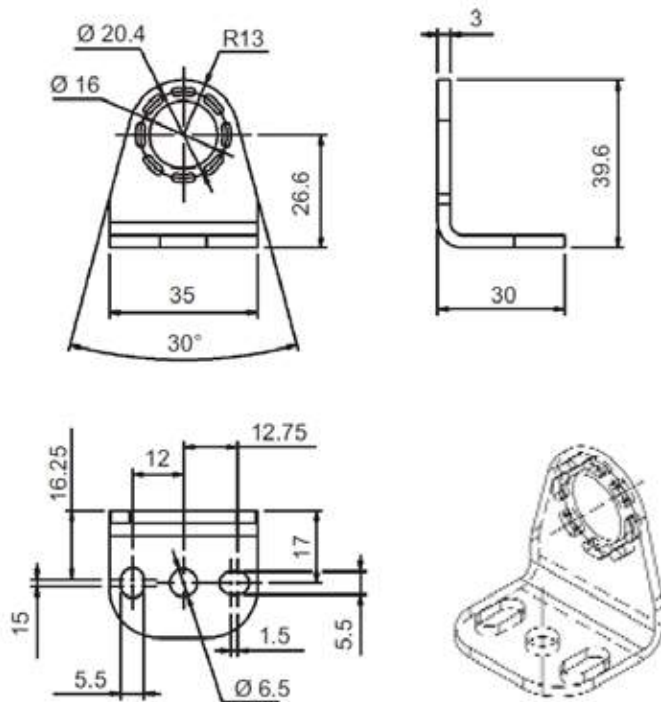

## MIRRORS AND STANDS

In applications where the monitoring of an area is required, safety light curtains can be used together with mirror for perimetral protection.

DATALOGIC offers a series of stands with adjustable mirrors already in place for 2 , 3 , 4 beam safety light curtains (SG-PSM), or the option to build a configuration, applying SG-DM mirrors to SE-S or SG-PSB stands.

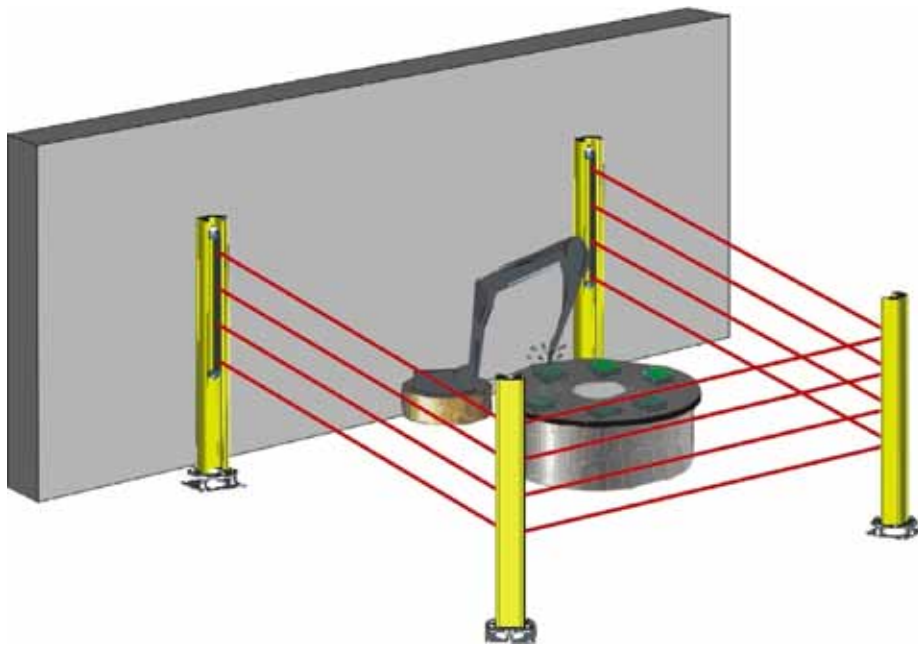

When using deviating mirrors, consider the following points:

1. The mirror length has to be at least 100 mm greater than the length of the light curtain's protected area.

Ex. For a SG2-30-090-00-E (protection height = 900 mm), choose a SG-DM 1200

2. Each beam reflection decreases the operating range of the safety light curtain.

To estimate the actual distance that can be reached, apply the following table to the starting range of the safety light curtain in absence of mirrors.

MIRRORS	RANGE BETWEEN TRANSMITTER AND RECEIVER				
0	6,0	19,0	20,0	50,0	60,0
1	5,1	16,2	17,0	42,5	51,0
2	3,9	12,4	13,0	32,5	39,0
3	3,0	9,5	10,0	25,0	30,0

## Stands with adjustable mirrors (SG-PSM)

Stands with adjustable pre-mounted mirrors, to protect them from accidental collisions.

An industrial steel base made with 2 plates, dowels and spheric level for adjustment of the vertical axis, slots for angular adjustment.

The effect of collisions, vibrations and uneven floor surfaces can be compensated by using SG-P plate kit (to be ordered separately).

MODEL	DESCRIPTION	ORDER NUMBER
SG-PSM-2-500	Protective stand with 2 mirrors H=500 mm	95ASE2300
SG-PSM-3-800	Protective stand with 3 mirrors H=800 mm	95ASE2310
SG-PSM-4-900	Protective stand with 4 mirrors H=900 mm	95ASE2320
SG-PSM-4-1200	Protective stand with 4 mirrors H=1200 mm	95ASE2330

SG-PSM-2-500

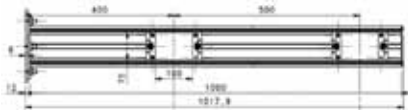

SG-PSM-3-800

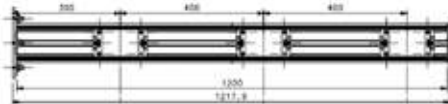

SG-PSM-4-900

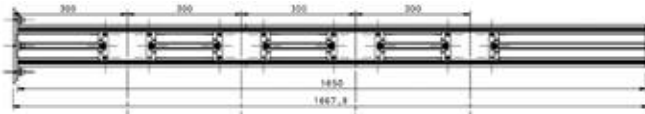

SG-PSM-4-1200

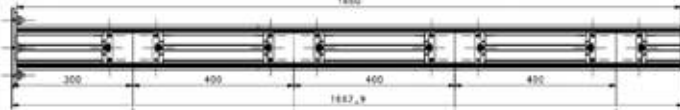

### PLATE KIT SG-P

MODEL	DESCRIPTION	ORDER NUMBER
SG-P	Plate kit for protective stands	95ASE2290
<b>COMPATIBILITY</b>		
	protection stands SG-PSB mirror stands SG-PSM	

#### NOTES

The kit includes two plates and three springs, to compensate the effect of collisions, vibrations and uneven floor surfaces.

The plate kit can be used with protection stands SG-PSB and with mirror stands SG-PSM

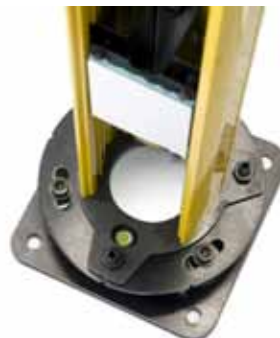
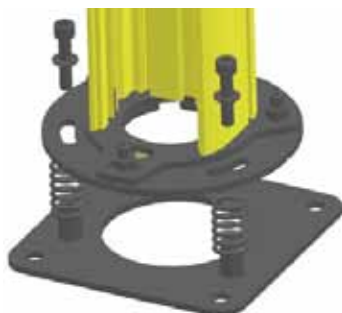



## Mirrors

### MIRRORS FOR FINGER AND HAND PROTECTION SAFETY LIGHT CURTAINS (SG-DM)

MODEL	DESCRIPTION	ORDER NUMBER
SG-DM 600	Deviating mirror version 600 mm	95ASE1680
SG-DM 900	Deviating mirror version 900 mm	95ASE1690
SG-DM 1200	Deviating mirror version 1200 mm	95ASE1700
SG-DM 1650	Deviating mirror version 1650 mm	95ASE1710
SG-DM 1900	Deviating mirror version 1900 mm	95ASE1720

#### NOTES

1. To mount these mirrors into the stands SG-PSB, order ST-PS-DM mounting kit
2. To mount these mirrors to columns SE-S, order one ST-DM mounting kit

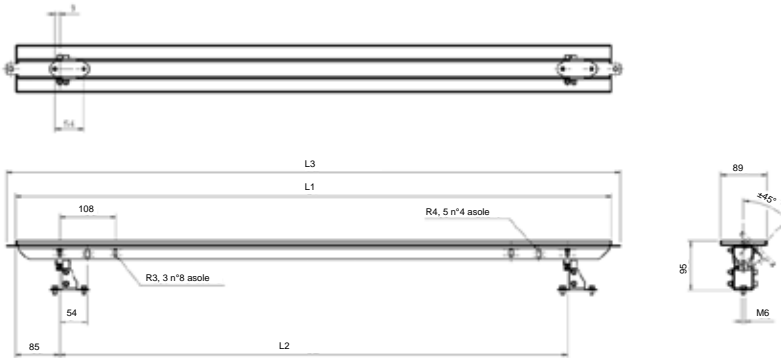

The image includes the mirror SG-DM and two bracket mounting kits ST-DM.

	L1 (mm)	L2 (mm)	L3 (mm)
SG -DM 600	545	376	580
SG -DM 900	845	676	880
SG -DM 1200	1145	976	1180
SG -DM 1650	1595	1426	1630
SG -DM 1900	1845	1676	1880

# ACCESSORIES | MIRRORS AND STANDS

## SINGLE BEAM MIRROR

MODEL	DESCRIPTION	ORDER NUMBER
SG-DM 150	Deviating mirror version 150 mm	95ASE1670

### NOTES

1. To mount this mirror into the stands SG-PSB order ST-PS-DM mounting kit
2. To mount this mirrors to columns SE-S, order ST-DM mounting kit

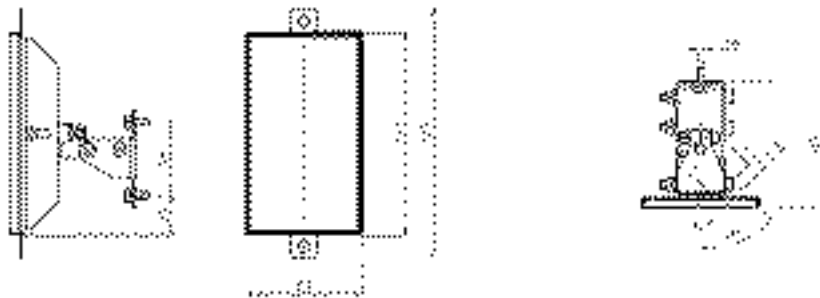

## Stands

### PROTECTIVE STANDS (SG-PSB) AND ACCESSORIES

MODEL	DESCRIPTION	ORDER NUMBER
SG-PSB 600	Protective Stand H=600 mm	95ASE2240
SG-PSB 1000	Protective Stand H=1000 mm	95ASE2250
SG-PSB 1200	Protective Stand H=1200 mm	95ASE2260
SG-PSB 1650	Protective Stand H=1650 mm	95ASE2270
SG-PSB 1900	Protective Stand H=1900 mm	95ASE2280

### COMPATIBILITY

All SG Series Light Curtains SG-DM Mirrors

### FLOOR COLUMNS (SE-S) AND ACCESSORIES

MODEL	DESCRIPTION	ORDER NUMBER
SE-S 800	Column and floor stand H = 800 mm	95ACC1730
SE-S 1000	Column and floor stand H = 1000 mm	95ACC1740
SE-S 1200	Column and floor stand H = 1200 mm	95ACC1750
SE-S 1500	Column and floor stand H = 1500 mm	95ACC1760
SE-S 1800	Column and floor stand H = 1800 mm	95ACC1770

### COMPATIBILITY

All SG Series Light Curtains SG-DM Mirrors

Stands SE-S

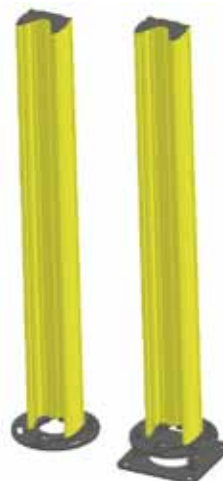
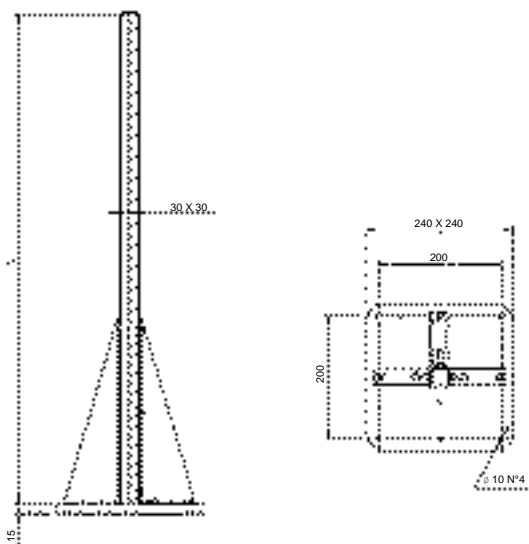

Stands SG-PSB

## Mounting kits for mirrors

### MOUNTING KIT FOR SG-DM MIRRORS ON SE-S FLOOR COLUMNS

MODEL	DESCRIPTION	ORDER NUMBER
ST-DM	Deviating mirror SG-DM mounting kit	95ASE1940
<b>COMPATIBILITY</b>		
	SG-DM Mirrors on SE-S floor columns	

**NOTE**

For each mirror (SG-DMxxx) order 1 kit.

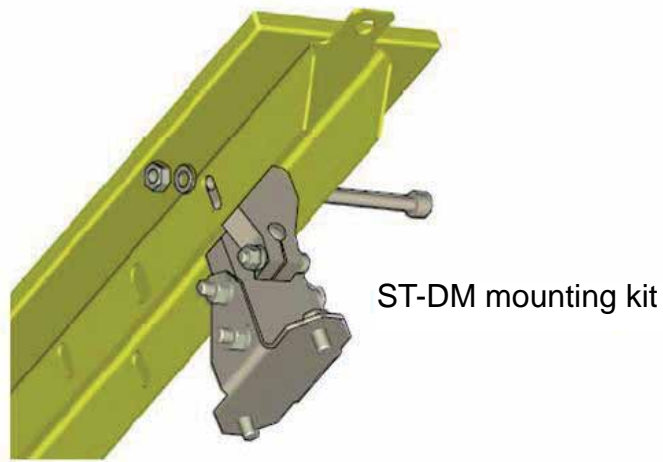

### MOUNTING KIT FOR SG-DM MIRRORS AND SG-PSB PROTECTIVE STANDS

MODEL	DESCRIPTION	ORDER NUMBER
ST-PS-DM	Deviating mirror mounting kit (contains 2 T-nuts)	95ASE1770
<b>COMPATIBILITY</b>		
	SG-DM Mirrors in SG-PSB protective stands	

**NOTE**

For each mirror (SG-DM xxx) order 1 kit.

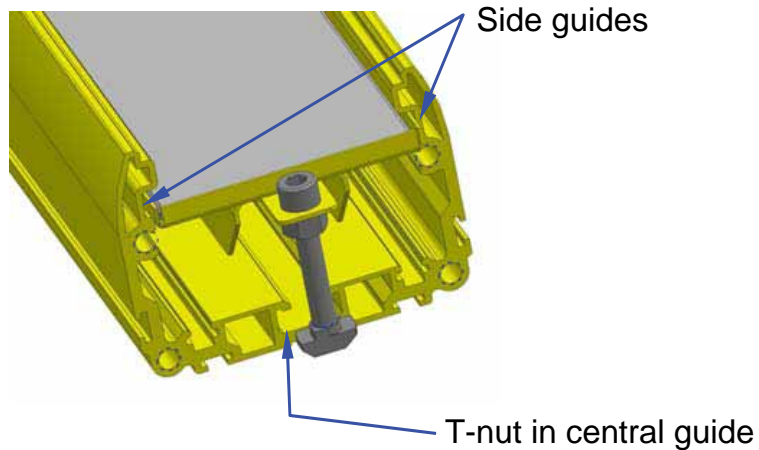

## Mounting kits for safety light curtains

MODEL	DESCRIPTION	ORDER NUMBER
ST-PS4-SG BODY	Protective stand mounting kit for SG BODY BIG (4 brackets)	95ASE1730
ST-PS6-SG BODY	Protective stand mounting kit for SG BODY BIG (6 brackets)	95ASE1740
ST-PS4-SG-SE	Protective stands mounting kit for SG/SE (4 brackets)	95ASE1750
ST-PS6-SG-SE	Protective stands mounting kit for SG/SE (6 brackets)	95ASE1760
COMPATIBILITY		
ST-PSx-SG-SE	SG2 BASE SG2 EXTENDED SG2 MUTING SG4 BASE SG4 EXTENDED SG BODY COMPACT	
ST-PSx-SG BODY	SG BODY BIG SG BODY REFLECTOR	

### NOTES

- 1) Each kit allows to install an element (emitter or receiver, active part or passive part) of a light curtain.  
To install both elements of the light curtain, order 2 kits of the same type.
- 2) For light curtains with height  $\geq 1200$  mm, order the 6 brackets kits (ST-PS6-SG xxxx)

## ACCESSORIES FOR MUTING

### Muting Arms, Brackets, Cables

Some models of Safety Light Curtains series SG BODY COMPACT MUTING and SG BODY REFLECTOR MUTING are provided with active/passive muting arms in the packaging, but it's also possible to add muting arms as accessories (if the light curtain has integrated muting function).

Instead of using the active/passive arm couple, in which on side is an active sensor, and the other is a passive reflector, in order to reach longer operating distance or to contrast the effect of environmental conditions, is possible to order also 'F/G' muting arm couples, composed by an emitter and a receiver arm.

**IMPORTANT NOTICE:** For safety reasons, L muting arms should be used only for openings through which goods must exit from the dangerous area; for openings in which goods must enter the dangerous area, as well as for bi-directional movements, use T muting arms.



#### ACTIVE/PASSIVE ARMS

MODEL	DESCRIPTION	ORDER NUMBER
SG-L-ARMS V2	Active/Passive arms Couple for L muting	95ASE1861
SG-T-ARMS V2	Active/Passive arms Couple for T muting	95ASE1871
SG-AS-ARM V2	Active sensor single arm	95ASE1841
SG-PR-ARM V2	Passive reflector single arm	95ASE1851

#### EMITTER/RECEIVER ARMS

SG-F1-G1-ARMS	Emitter/Receiver arms couple (first couple)	95ASE1880
SG-F2-G2-ARMS	Emitter/Receiver arms couple (second couple)	95ASE1890

# ACCESSORIES | ACCESSORIES FOR MUTING

## BRACKETS AND CABLES

MODEL	DESCRIPTION	ORDER NUMBER
SG-CB-B	Muting arms mounting bracket kit for BIG series	95ASE1920
SG-CB-C	Muting arms mounting bracket kit for COMPACT series	95ASE1930
CV-Y1-02-B-007	M12 4 pole T muting cable	95ACC2560
CV-L1-02-B-007	M12 4 pole L muting cable	95ACC2570

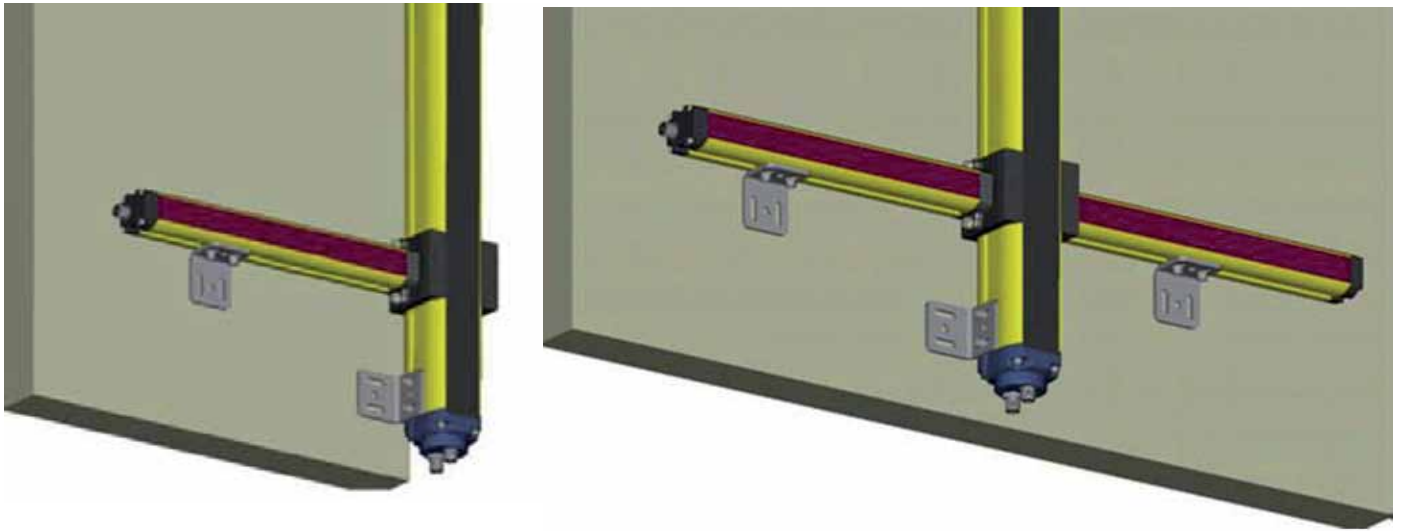

## COMPATIBILITY AND OPERATING DISTANCES

MUTING ARM	LIGHT CURTAIN	OPERATING DISTANCE
SG-L-ARMS V2 SG-T-ARMS V2	SG BODY COMPACT MUTING SG2 MUTING SG4 EXTENDED	0.5 ... 3 m
SG-AS-ARM V2 SG-PR-ARM V2	SG BODY COMPACT MUTING SG BODY REFLECTOR MUTING SG2 MUTING SG4 EXTENDED SG4 BODY BIG MUTING SHORT RANGE <sup>A</sup>	0.5 ... 3 m
SG-F1-G1-ARMS SG-F2-G2-ARMS	SG2 BODY BIG MUTING SG4 BODY BIG MUTING SHORT RANGE <sup>A</sup> SG BODY COMPACT MUTING	0.5 ... 7 m

### NOTES

<sup>A</sup> SG4 BODY MUTING LONG RANGE (whose operating range is 6 ... 60 m) can't be used in combination with muting arms.

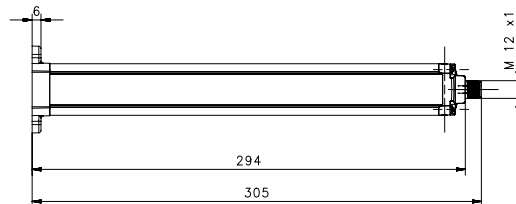
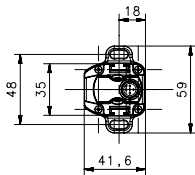

## SG-AS-ARM V2

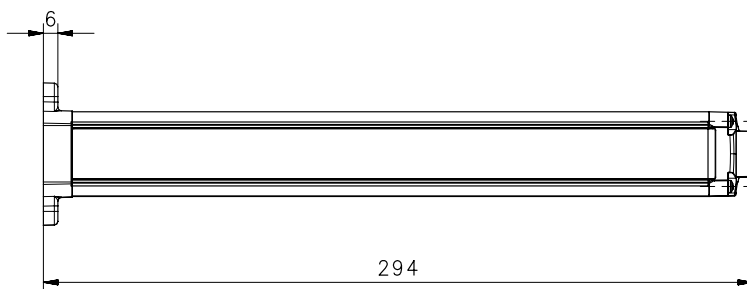
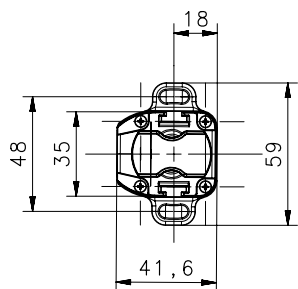

## SG-PR-ARM V2

SG-T-ARMS  
T COUPLE ARMS  
95ASE1871



SG-L-ARMS  
L COUPLE ARMS  
95ASE1861

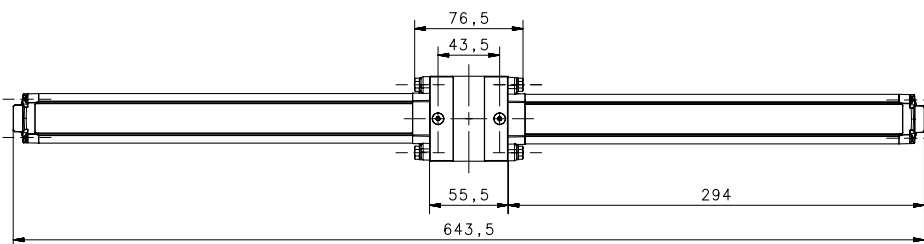
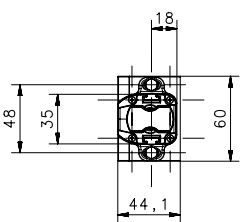
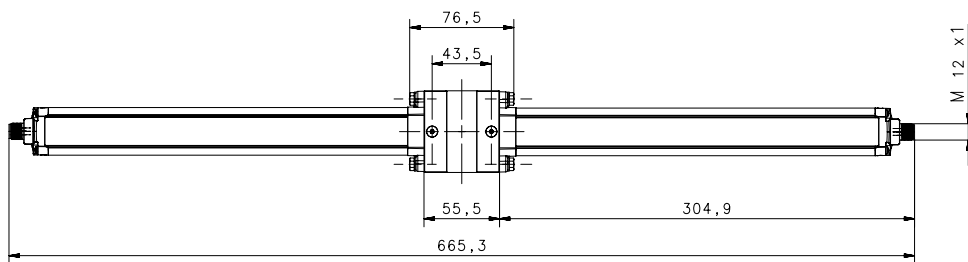
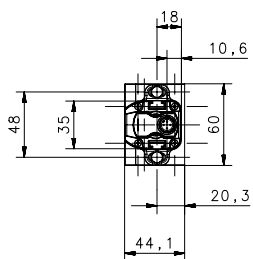
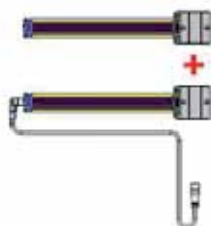

SG-PR-ARM V2 (T muting cable CV-Y1-02-B-007 is included)

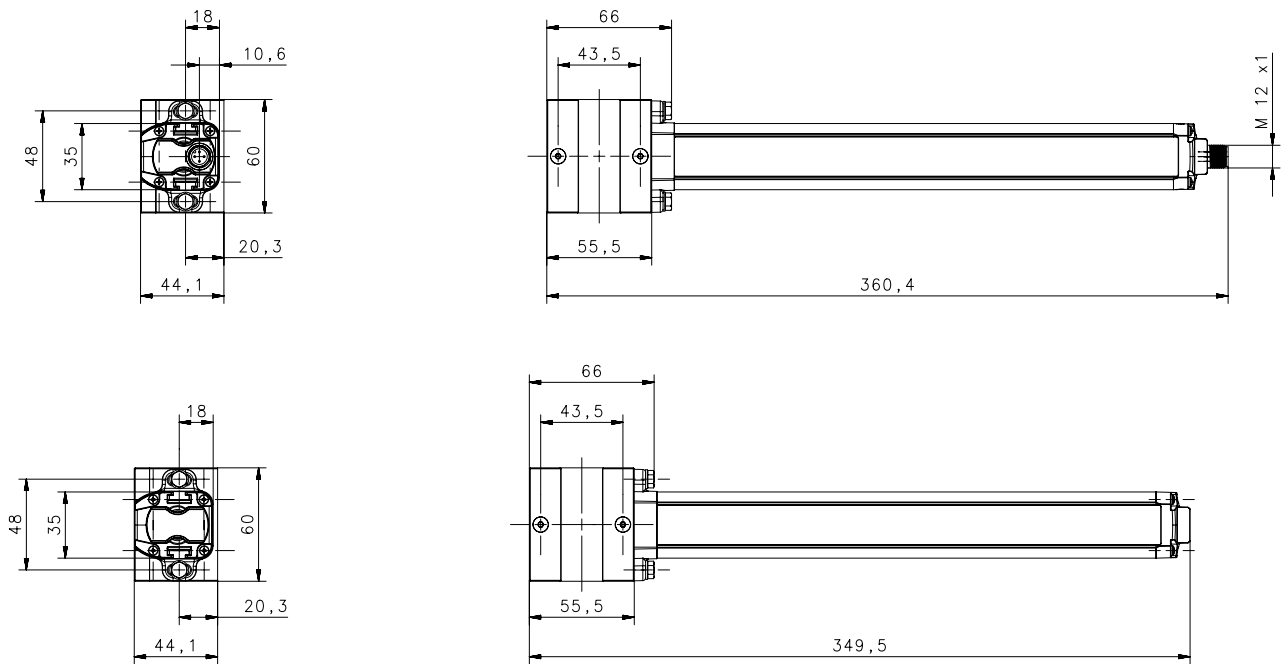

SG-L-ARMS V2 (L muting cable CV-L1-02-B-007 is included)

## ORDERING SUMMARY TABLE FOR MUTING ACCESSORIES

SAFETY LIGHT CURTAIN	MUTING	TYPE	SG-L-ARMS V2	SG-T-ARMS V2	SG-AS-ARM V2	SG-PR-ARM V2	SG-CB-B	SG-CB-C	CV-L1-02-B-007	CV-Y1-02-B-007	SG-F1G1-ARMS	SG-F2G2-ARMS
SG BODY BIG MUTING	L	RRX			1	1	2		1			
	T	RRX			2	2	2			1		
	L	F/G					2		2		1	
	T	F/G					2			2	1	1
SG BODY REFLECTOR (ACTIVE AND PASSIVE SIDES)	L	RRX			1	1	2		1			
	T	RRX			2	2	2			1		
SG BODY COMPACT MUTING	L	RRX	1									
	L	RRX			1	1		2	1			
	T	RRX		1								
	T	RRX			2	2		2		1		
	L	F/G						2	2		1	
	T	F/G						2		2	1	1
SG2 MUTING SG4 EXTENDED	L	RRX	1									
	T	RRX		1								

### NOTES

RRX = Active/Passive retroreflective muting arms  
F/G = Emitter/Receiver muting arms

### EXAMPLES

- 1) To realize an L muting with retroreflective arms starting from a SG BODY COMPACT MUTING, order the complete kit SG-L-ARMS or, in alternative, the following: 1x SG-AS-ARM, 1x SG-PR-ARM, 2x SG-CB-C, 1x CV-L1-02-B-007 .
- 2) To realize a T muting with emitter/receiver arms, starting from a SG BODY BIG MUTING, order the following: 2x SG-CB-B, 2x CV-Y1-02-B-007, 1x SG-F1G1-ARMS, 1x SG-F2G2-ARMS.



## Muting lamps

Depending on the risk assessment, an indicator to show when the muting function is active can be necessary. This indicator shows that the normal protective function of the light curtain is temporary suspended. The muting indicator should have sufficient brightness and be installed so as to be readily visible from any foreseeable position where a person can attempt to access the hazard zone.



MODEL	DESCRIPTION	ORDER NUMBER
LMS	Muting lamp	95ASE1830
LMS-1	Modular Muting lamp	95ACC1990
LMS-2	Muting lamp - horizontal mounting	95ACC2000
LMS-3	Muting lamp - vertical mounting	95ACC2010
SU-LMS-1A	Basic support for LMS-1	95ACC2020
SU-LMS-1B	Tower module for LMS-1	95ACC2030

### NOTES

- 1) LMS, LMS-1, LMS-2 and LMS-3 are provided with incandescent light bulbs (3W, 24V)
- 2) LMS-1 has to be ordered with one of the two supports: SU-LMS-1A or SU-LMS-1B
- 3) External muting lamp is also available con Muting Connection Box SG-SRT2

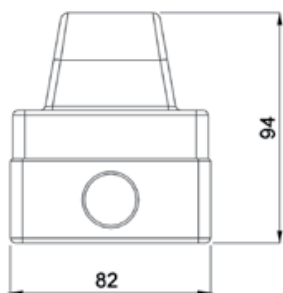
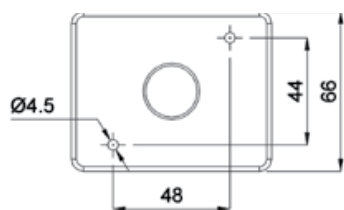

LAMP LMS

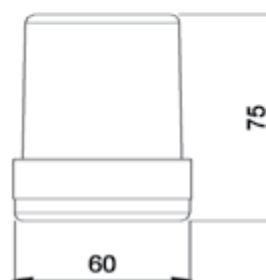
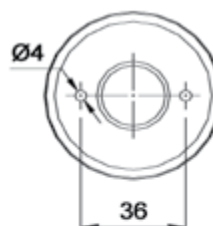

LAMP LMS-2

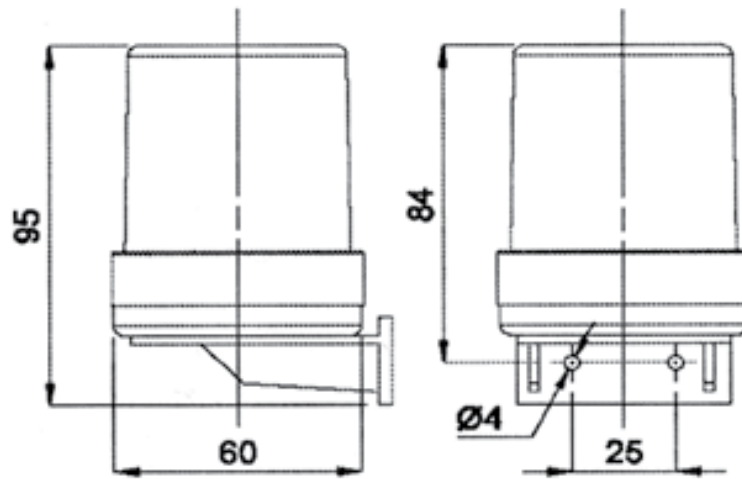

LAMP LMS-3

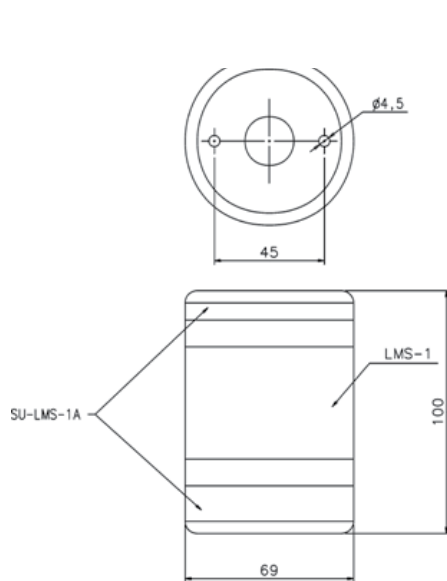

SUPPORT SU-LMS-1A  
LAMP LMS-1



SUPPORT SU-LMS-1B  
LAMP LMS-1

## SAFETY UNITS AND INTERFACES

SE-SR2 is a safety unit that can be used in combination with every DATALOGIC Safety Light Curtains.

It provides dual-channel operation without detection of shorts across contacts.

Short circuits and earth faults in the pushbutton circuit are detected.

CS-ME is an interface with two forcibly guided relays, providing 3 NO contacts. The diagnostic function must be performed by the Safety Light Curtains through External Device Monitoring function.



	SE-SR2	CS-ME
<b>GENERAL DATA</b>		
PL (EN ISO 13849-1)	e	up to e (depending on ESPE)
SIL (IEC 61508)	3	up to 3 (depending on ESPE)
<b>ELECTRICAL DATA</b>		
Power supply	24 Vdc -15/+10%	24 Vdc -/+20%
Outputs		
Safe outputs (Cat. 4)	3 NO	3 NO
Auxiliary outputs	1 NC	1 NC
Response time		
Following input going OFF	typ. 10 ms, max. 20 ms	15 ms
With power failure	typ. 70 ms, max. 120 ms	15 ms
Recovery time		
Following inputs going ON	50 ms	40 ms
After power on	150 ms	40 ms
<b>MECHANICAL AND ENVIRONMENTAL DATA</b>		
Operating temperature	-10 ... +55°C	-25 ... +55°C
Humidity	15 ... 95 % (no condensation)	15 ... 95 % (no condensation)
Mechanical protection	IP20	IP20
<b>FUNCTIONS</b>		
Reset modes	Automatic/Manual/Monitored	Automatic
External Device Monitoring	Available on SE-SR2	Must be activated on Safety Light Curtain (ESPE)
<b>COMPATIBILITY</b>		
	All DATALOGIC Safety Light Curtains	All DATALOGIC Safety Light Curtains with EDM function:  SG2 EXTENDED SG2 MUTING SG2 BASE, SG4 BASE SG BODY COMPACT SG BODY BIG SG BODY REFLECTOR SG BODY COMPACT SG4 EXTENDED

# ACCESSORIES | SAFETY UNITS AND INTERFACES

## SE-SR2 DIMENSIONS

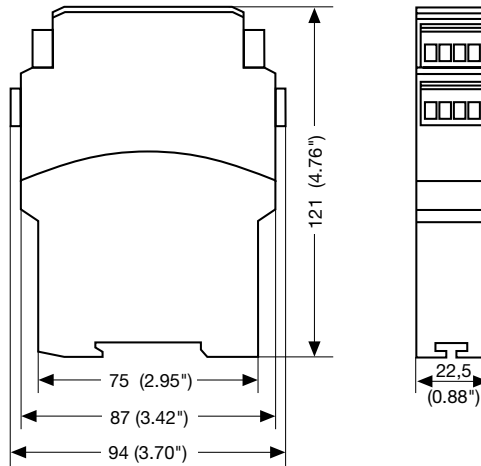

## CS-ME INTERNAL DIAGRAM

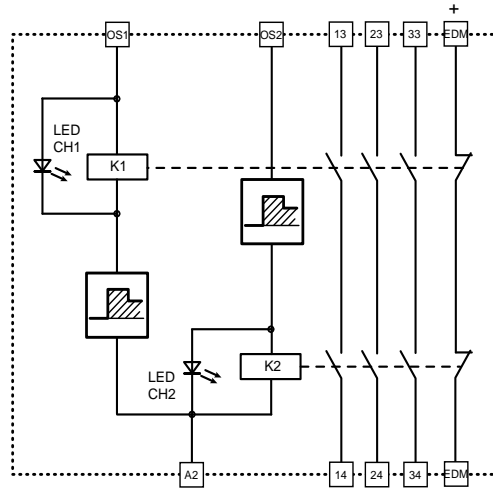

## CS-ME WIRING DIAGRAM

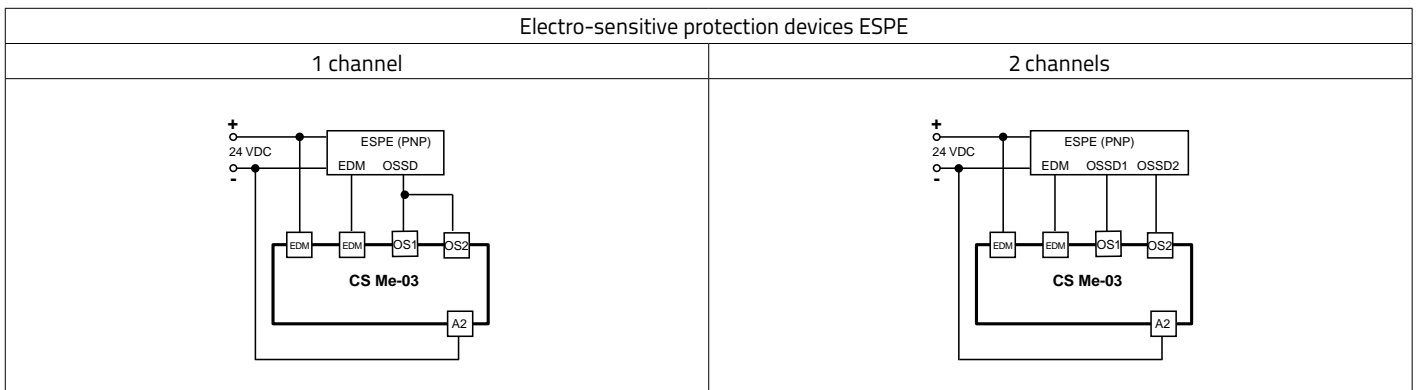

MODEL	DESCRIPTION	ORDER NUMBER
SE-SR2	Safety Unit	95ACC6170
CSME-03VU24-Y14	Forcibly guided relay interface	95ASE1270

## Connection Boxes

SG-SRT1 and SG-SRT2 are interfaces provided with redundant forcibly guided relays, supplying a ready operator interface to restart or override the Safety Light Curtain, and have muting indication.



**SG-SRT-1**



**SG-SRT-2**

	SG-SRT1	SG-SRT2
<b>ELECTRICAL DATA</b>		
Power supply	24 Vdc +/- 20%	
Safe outputs	2 NO	
Max. switchable voltage	250 Vac	
Max. switchable current	2 A	
<b>FUNCTIONS</b>		
Reset mode	Automatic/Manual	
	Test	
	Reset	
	Restart	
	Override	
	---	Muting state indication
<b>COMPATIBILITY</b>		
	SG BODY COMPACT MUTING SG BODY BIG MUTING SG BODY REFLECTOR MUTING	SG BODY BIG MUTING SG BODY REFLECTOR MUTING

### NOTE

SG-SRT1 and SG-SRT2 provide internal or external EDM signal to the Safety Light Curtain: to operate safely, EDM monitoring function must be activated on the Safety Light Curtain and correct wiring must be followed.  
For further information refer to SG-SRT1/2 manual and the used Safety Light Curtain manual.

# ACCESSORIES | SAFETY UNITS AND INTERFACES

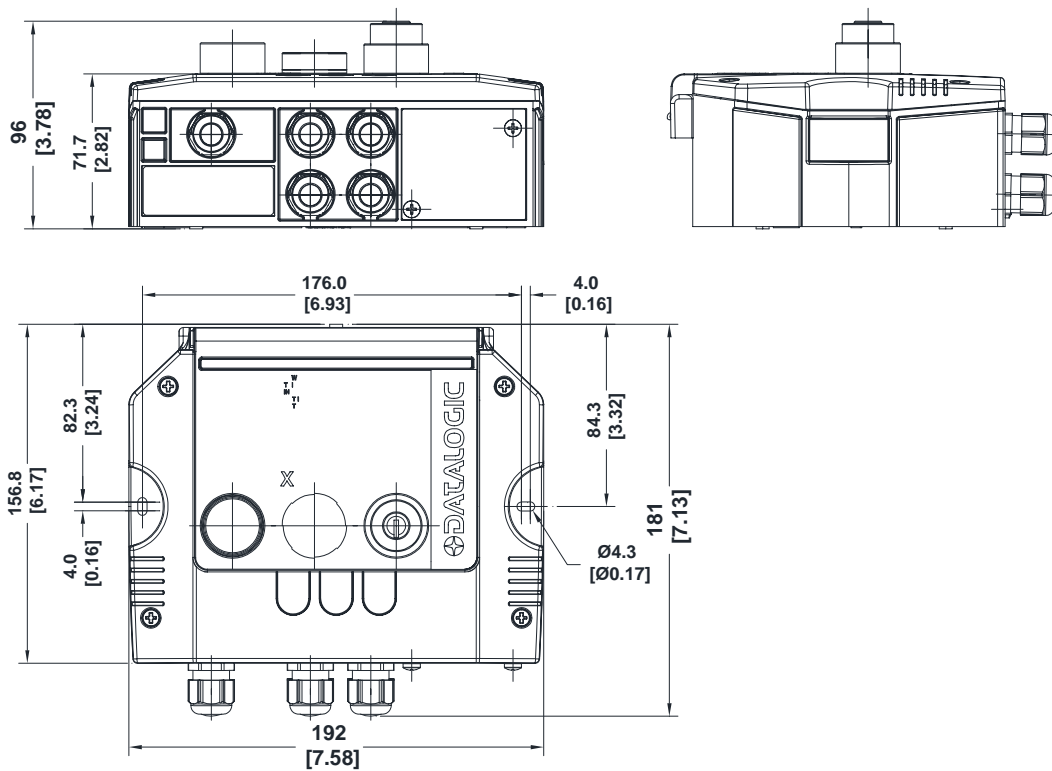

MODEL	DESCRIPTION	ORDER NUMBER
SG -SRT-1	Muting connection box	95ASE2050
SG -SRT-2	Muting connection box with lamp	95ASE2060

## ACCESSORIES

# OTHER ACCESSORIES

### Protection tubes

SG-IP69K are PMMA acrylic tubes used to protect and seal safety light curtains.

The IP protection of the safety light curtain is increased to IP67, IP68 and IP69K.

A Gore-Tex membrane on the caps prevents water or dirt entering as well as internal condensation.

MODEL	DESCRIPTION	ORDER NUMBER
SG -IP69K 150	Tubular IP69K H=150mm	95ASE 1290
SG -IP69K 300	Tubular IP69K H=300mm	95ASE 1300
SG -IP69K 450	Tubular IP69K H=450mm	95ASE 1310
SG -IP69K 600	Tubular IP69K H=600mm	95ASE 1320
SG -IP69K 750	Tubular IP69K H=750mm	95ASE 1330
SG -IP69K 900	Tubular IP69K H=900mm	95ASE 1340
SG -IP69K 1050	Tubular IP69K H=1050mm	95ASE 1350
SG -IP69K 1200	Tubular IP69K H=1200mm	95ASE 1360
SG -IP69K 1350	Tubular IP69K H=1350mm	95ASE 1370
SG -IP69K 1500	Tubular IP69K H=1500mm	95ASE 1380
SG -IP69K 1650	Tubular IP69K H=1650mm	95ASE 1390
SG -IP69K 1800	Tubular IP69K H=1800mm	95ASE 1400

#### COMPATIBILITY

SG2 BASE, SG2 EXTENDED, SG4 BASE

MODEL	DESCRIPTION	ORDER NUMBER
SG-IP69K-2-050	Tubular IP69K H=500mm	95ASE1410
SG-IP69K-3-080	Tubular IP69K H=800mm	95ASE1420
SG-IP69K-4-090	Tubular IP69K H=900mm	95ASE1430
SG-IP69K-4-120	Tubular IP69K H=1200mm z	95ASE1440

#### COMPATIBILITY

SG BODY COMPACT

#### NOTES

1) Each package contains the necessary to protect a single unit (emitter or receiver).

To protect both elements of a couple, order two pieces

2) Tubular PMMA POLICRIL material chemical resistance table is available on product's datasheet.



## DIMENSIONS

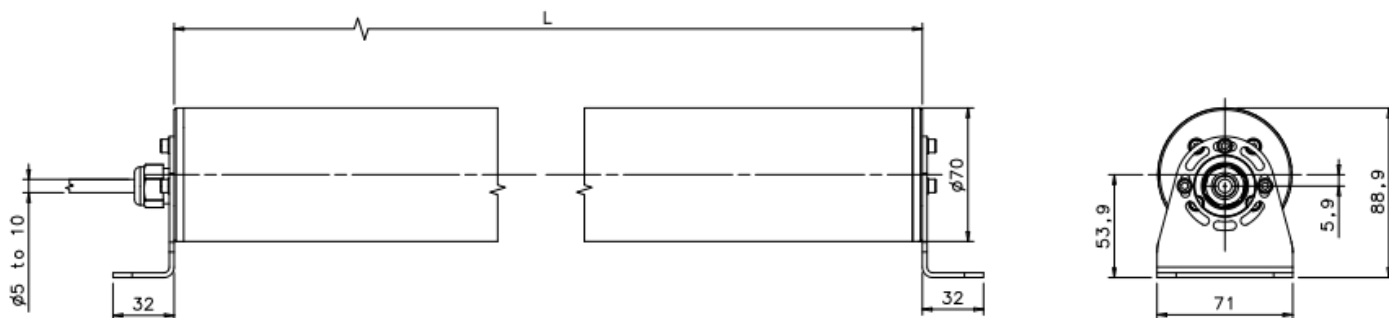

MODEL	L (mm)
SG-IP69K 150	373.5
SG-IP69K 300	520.7
SG-IP69K 450	670.8
SG-IP69K 600	820.7
SG-IP69K 750	970.8
SG-IP69K 900	1120.7
SG-IP69K 1050	1270.7
SG-IP69K 1200	1420.8
SG-IP69K 1350	1570.7
SG-IP69K 1500	1720.8
SG-IP69K 1650	1870.8
SG-IP69K 1800	2020.8
SG-IP69K-2-050	808
SG-IP69K-3-080	1108
SG-IP69K-4-090	1208.5
SG-IP69K-4-120	1508.5



## Lens shields

The LENS SHIELD accessory for safety light curtains is composed of a PMMA Altuglas plate that can be mounted on the front glass of the safety light, ensuring an effective protection against dust, chips and incandescent drops deriving from material working near the safety light curtain.



MODEL	DESCRIPTION	ORDER NUMBER
SG -LS 150	Lens shield 150 mm	95ASE 1450
SG -LS 300	Lens shield 300 mm	95ASE 1460
SG -LS 450	Lens shield 450 mm	95ASE 1470
SG -LS 600	Lens shield 600 mm	95ASE 1480
SG -LS 750	Lens shield 750 mm	95ASE 1490
SG -LS 900	Lens shield 900 mm	95ASE 1500
SG -LS 1050	Lens shield 1050 mm	95ASE 1510
SG -LS 1200	Lens shield 1200 mm	95ASE 1520
SG -LS 1350	Lens shield 1350 mm	95ASE 1530
SG -LS 1500	Lens shield 1500 mm	95ASE 1540
SG -LS 1650	Lens shield 1650 mm	95ASE 1550
SG -LS 1800	Lens shield 1800 mm	95ASE 1560
SG -LS 2	Lens shield 2 beams 500 mm	95ASE 1570
SG -LS 3	Lens shield 3 beams 800 mm	95ASE 1580
SG -LS 4-900	Lens shield 4 beams 900 mm	95ASE 1590
SG -LS 4-120	Lens shield 4 beams 1200 mm	95ASE 1600
SG -LS-MC 4	Elastic fastner for lens shield (kit 4pcs.)	95ASE 1810
COMPATIBILITY		
	SG-LS xxxx	SG2 BASE SG2 EXTENDED SG4 BASE
	SG-LS 2 SG-LS 3 SG-LS 4-900 SG-LS 4-120	SG BODY COMPACT

### NOTES

- 1) Each package contains the necessary to protect a single unit (emitter or receiver). To protect both elements of a couple, order two pieces
- 2) Five plates are supplied in the package for replacements
- 3) The length indicated in the description is the height of the light curtains that can be used with the lens shield, for the actual dimension, refer to the technical datasheet.

## Laser pointer



### LASER POINTER

MODEL	DESCRIPTION	ORDER NUMBER
SG-LP	Laser pointer	95ASE5590
<b>COMPATIBILITY</b>		
	All SG Series Safety Light Curtains	

## Communication interface

### DONGLE

MODEL	DESCRIPTION	ORDER NUMBER
SG4-DONGLE	Ethernet adaptor	95ASE2080
<b>FUNCTIONS</b>		
1) Ethernet connection (TCP/IP) to Monitoring and Configuration Software SG4-E GUI. 2) Configuration cloning 3) Error logging 4) Configuration logging		
<b>NOTE</b>		
To connect SG-DONGLE directly to a PC, order Ethernet cable CAB-ETH-M01		
<b>COMPATIBILITY</b>		
	SG4 EXTENDED	



### DONGLE - PC ETHERNET CABLE

MODEL	DESCRIPTION	ORDER NUMBER
CAB-ETH-M01	M12-IP67 ETHERNET CAB. (1M)	93A051346

## Test pieces



MODEL	DESCRIPTION	ORDER NUMBER
TP-14	Test piece Ø 14 mm	95ACC 1630
TP-20	Test piece Ø 20 mm	95ACC 1640
TP-30	Test piece Ø 30 mm	95ACC 1650
TP-35	Test piece Ø 35 mm	95ACC 1660
<b>COMPATIBILITY</b>		
	All SG Series Safety Light Curtains	

# APPENDIX



# APPENDIX



## SAFETY STANDARDS REFERENCE LIST

The following is a list of international standards for Safety of Machinery and correct design use of safety systems.

### *1. General principles*

**EN ISO 12100: 2010** Safety of machinery – General principles for design – Risk assessment and risk reduction.

### *2. Safety systems design and validation*

**EN ISO 13849-1: 2008** Safety of machinery – Safety-related parts of control systems. Part 1: General principles for design

**EN ISO 13849-2: 2012** Safety of machinery – Safety-related parts of control systems. Part 2: Validation.

**EN 62061 / AC 2010** Safety of machinery. Functional safety of safety-related electrical/electronic/programmable electronic control systems.

### *3. Electrosensitive protective equipment*

**EN 61496-1 / AC: 2010** Safety of machinery: electrosensitive protective equipment. Part 1: General prescriptions and tests.

**IEC 61496-2: 2006** Safety of machinery: electrosensitive protective equipment - Part 2: Particular requirements for equipment using active optoelectronic protective devices.

### *4. Safety distances*

**EN ISO 13855: 2010** Safety of machinery – Positioning of safeguards with respect to the approach speeds of parts of the human body.

## DEFINITIONS

### **1. AOPD: Active Optoelectronic Protective Device**

Device whose sensing function is performed by opto-electronic emitting and receiving elements detecting the interruption of optical radiations generated, within the device, by an opaque object present in the specified detection zone (or for a light beam device, on the axis of the light beam).

### **2. EAA: Effective Aperture Angle**

Maximum angle of deviation from the optical alignment of the emitting element(s) and the receiving element(s) within which the AOPD continues in normal operation.

### **3. EDM: External Device Monitoring**

Means by which the electro-sensitive protective equipment (ESPE) monitors the state of control devices which are external to the ESPE.

### **4. ESPE: Electro-Sensitive Protective Equipment**

Assembly of devices and/or components working together for protective tripping or presence sensing purposes and comprising as a minimum

- a sensing device;
- controlling/monitoring devices;
- output signal switching devices and/or a safety-related data interface.

### **5. Light curtain**

AOPD comprising an integrated assembly of one or more emitting element(s) and one or more receiving element(s) forming a detection zone with a detection capability specified by the supplier. A light curtain with a large detection capability is sometimes referred to as a light grid.

### **6. OSSD: Output Signal Switching Device**

Component of the electro-sensitive protective equipment (ESPE) connected to the machine control system which, when the sensing device is actuated during normal operation, responds by going to the OFF-state.

### **7. PL: Performance Level**

Discrete level used to specify the ability of safety-related parts of control systems to perform a safety function under foreseeable conditions.

### **8. Response time**

Maximum time between the occurrence of the event leading to the actuation of the sensing device and the output signal switching devices (OSSD) achieving the OFF-state.

### **9. SIL: Safety Integrity Level**

Discrete level for specifying the safety integrity requirements of the safety functions to be allocated to the Electric / Electronic / Programmable Electronic safety-related systems, where safety integrity level 4 has the highest level of safety integrity and safety integrity level 1 has the lowest.

## SAFETY DISTANCE CALCULATION



- Properly install the light curtains in accordance with the user manual and applicable local safety regulations (OSHA, ANSI, European standards as EN ISO 13855 'Safety of Machinery - Positioning of safeguards with respect to the approach speeds of parts of the human body").
- Consult DLIA Technical support before installing light curtains if you have questions, need information or assistance about the products.

**Failure to comply with these instructions could result serious injury**

The positioning of light curtains and light grids must comply with the international standard EN ISO13855, that provides a methodology to determine the minimum distance to a hazard zone from the detection zone, based on values for approach speeds of parts of the human body.

If a type-C standard exists for the machine, the distance specified should be used. If there is no type-C standard, the equations in EN ISO 13855 can be used to calculate it.

The factors to be taken in account are:

T1	Response time of the light curtain
T2	Machine stopping time
d	Resolution of the light curtain
K	Speed of the body or parts of the body (parameter given by the standard)

### 1. Vertical installation

#### 1.1 Equation for the calculation of the minimum distance

The detection zone is horthogonal to the direction of approach to the hazard zone

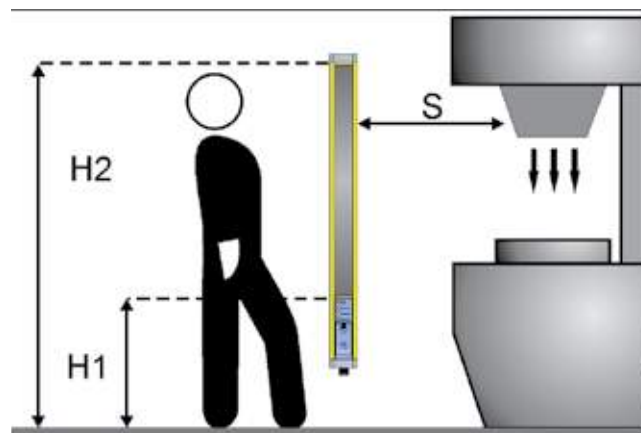

Fig. 3 – Minimum installation distance (vertical)

# APPENDIX

For light curtains with detection capability  $d \leq 40$  mm, the equation used to calculate the minimum distance  $S$  from a vertical detection zone horthogonal to the direction of approach to the hazard zone is:

$$S = K (T1 + T2) + C$$

Where  $C$  is an additional intrusion distance:

$$C = 8 (d - 14) \text{ mm if resolution } \leq 40 \text{ mm}$$
$$C = 850 \text{ mm if resolution } > 40 \text{ mm}$$

The equation must be first calculated using  $K = 2000$  mm/s.  
If the result  $S > 500$  mm, it can be recalculated with  $K = 1600$  mm/s.

The result  $S$  must in any case be:

$$S \geq 100 \text{ mm if } K = 2000 \text{ mm/s is used;}$$
$$S \geq 500 \text{ mm if } K = 1600 \text{ mm/s is used}$$

For light curtains with detection capability  $d > 40$ mm and multiple separate beams (body detection) the following values can be used:

$$C = 850 \text{ mm}$$
$$K = 1600 \text{ mm/s}$$

## 1.2 Positions of the beams above reference plane

When the safeguard is used only for the detection of whole body access:

- a) the height of the lowest beam shall be  $\leq 300$  mm to prevent access under the detection zone
- b) the height of the uppermost beam shall be  $\geq 900$  mm to prevent stepping over the detection zone.

EN13855 states that the heights for 2, 3 and 4 beams given in the following table have been found to be the best compromise between an adequate risk reduction and the most practical in application. Further protective measures to prevent access to the hazard zone can be required. For the lowest beam 400 mm can only be used when the risk assessment allows it.

NUMBERS OF BEAMS	HEIGHTS ABOVE REFERENCE PLANE (MM)
4	300, 600, 900, 1200
3	300, 700, 1100
2	400, 900

## 1.3 Circumventing of ESPE by reaching over the detection zone

If access to the hazard zone by reaching over the detection zone of vertically mounted electro-sensitive protective equipment cannot be excluded, an additional distance must be applied, depending on the height of the hazard zone and the height of upper edge of the ESPE detection zone. For reference, apply EN ISO 13855 Par. 6.5.



# APPENDIX

## 2. Horizontal installation

### 2.1 Equation for the calculation of the minimum distance

The detection zone is parallel to the direction of approach to the hazard zone

If the safety light curtain must be mounted in a horizontal position (Fig. 4), the distance between the dangerous area and the most distant optical beam must be equal to the value calculated using the following equation:

$$S = 1600 \text{ mm/s} (T1 + T2) + (1200 \text{ mm} - 0.4 H)$$

where:

T1 = Response time of the ESPE in seconds

T2 = Machine stopping time in seconds.

H = Beam height from ground

H shall not be greater than 1000 mm, and however for values greater than 300 mm the risk of an undetected access beneath the detection zone shall be taken in account during the risk assessment.

Furthermore, the lowest allowable height of the detection zone must satisfy this equation:

$$H_{\text{min}} = 15 (d - 50)$$

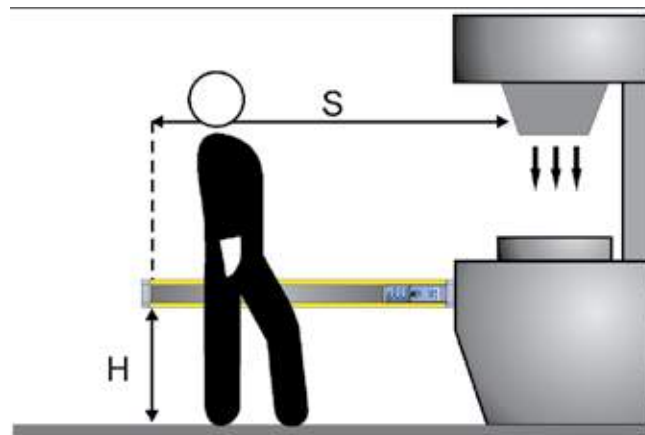
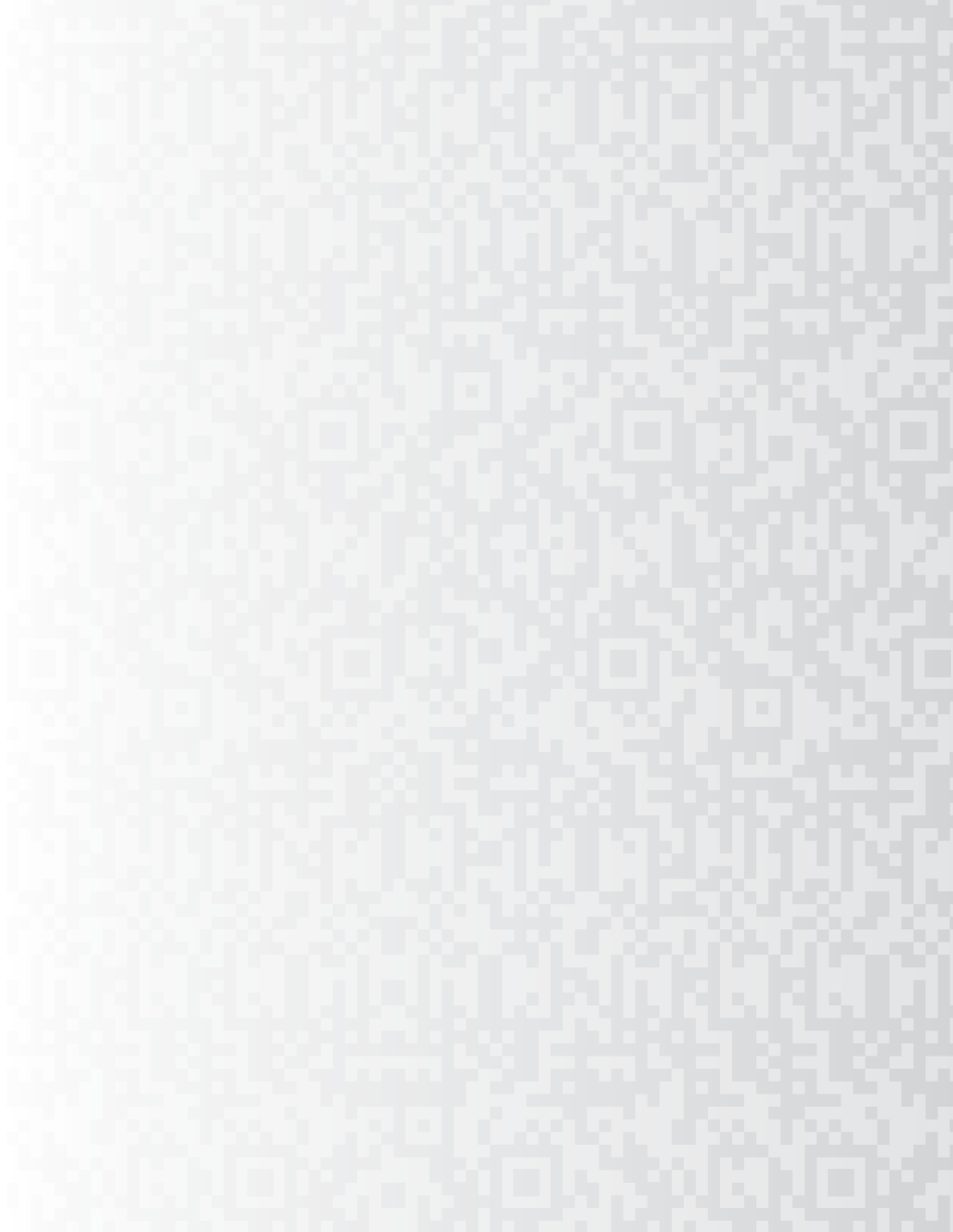

Fig. 4 – Minimum installation distance (horizontal)

# ANALYTICAL INDEX

AOPD: Active Optoelectronic Protective Device	93	SG4-DONGLE	89
Automatic restart	14	SG4-RBxL/T-xxx-00-W (SG BODY REFLECTOR MUTING active side)	43
Blanking	17	SG4-RBx-xxx-00-E (SG BODY REFLECTOR BASE active side)	43
CAB-ETH-M01	89	SG4-RBx-xxx-00-W (SG BODY REFLECTOR MUTING active side)	43
Cascading	13	SG4-RDBx (SG BODY REFLECTOR BASE passive side)	43
CS -A1-10-U-xx	41, 49, 55	SG4-RDBx (SG BODY REFLECTOR MUTING passive side)	43
CS-A1-02-U-xx	27	SG4-RDBxL/T (SG BODY REFLECTOR MUTING passive side)	43
CS-A1-03-U-xx	27, 34, 41, 49, 55	SG4-xx-xxx-00-E (SG4 BASE)	23
CS-A1-06-U-xx	27, 41, 49, 60	SG4-xx-xxx-00-P (SG4 EXTENDED)	51
CS-F1-80-B-xxxx	55	SG-AS-ARM	76
CS-G1-50-B-002	55	SG-BWS-T4	57
CS-G1-xx-B-002	55	SG-BWS-T4-MT	57
CS-ME	82	SG-CB-B	77
CS-R1-75-B-002	55	SG-CB-C	77
CV-A1-22-B-xx	34	SG-DM	72
CV-A1-26-B-xx	34	SG-F1-G1-ARMS	76
CV-L1-02-B-007	77	SG-F2-G2-ARMS	76
CV-Y1-02-B-007	77	SG-IP69K	86
DataVS-MK-01	58	SG-L-ARMS	76
Detection capability	12	SG-LP	89
Detection zone	12	SG-LS	88
EAA: Effective Aperture Angle	93	SG-P	71
EDM	14	SG-PR-ARM	76
ESPE: Electro-sensitive protective equipment	93	SG-PSB	73
External device monitoring	14	SG-PSM	71
GUI ( Graphical User Interface )	17	SG-SRT1	84
LMS	80	SG-SRT2	84
Manual restart	14	SG-T-ARMS	76
MICRO-18	58	SGx-Bx-xxx-00-E (SG BODY BIG BASE)	37
Muting	15	SGx-Bxxx-xxx-00-W-C (SG BODY BIG MUTING)	37
OSSD: Output Signal Switching Device	93	SGx-S/L/Tx-xxx-PP-W (SG BODY COMPACT MUTING)	29
Override	16	SGx-Sx-xxx-PP-E (SG BODY COMPACT BASE)	29
Performance level	11	SIL: Safety Integrity Level	93
PL (Performance level)	11	SINGLE BEAM SENSORS	56
Resolution	12	SL5	56
Response time	93	SP-40	58
Retroreflective light curtain	13	ST-5099	58
S5	56	ST-5100	58
SE-S	73	ST-DM	74
SE-SR2	82	ST-K4REAR-SG BODY BIG	67
SG BODY BIG BASE	36	ST-K4ROT	69
SG BODY BIG MUTING	36	ST-K4ROT-SG BODY BIG	68
SG BODY COMPACT BASE	28	ST-K4ROT-SG BODY COMPACT	69
SG BODY COMPACT MUTING	28	ST-KCASCADE-SG EXTENDED	67
SG BODY REFLECTOR BASE	42	ST-KPxMP	66
SG BODY REFLECTOR MUTING	42	ST-KSTD	64
SG2 BASE	22	ST-KxAV	65
SG2 EXTENDED	22	ST-KxOR	65
SG2 MUTING	50	ST-PS-DM	74
SG2-30-xxx-00-W (SG2 MUTING)	51	ST-PSx-SG BODY	75
SG2-xx-xxx-00-E-C (SG2 EXTENDED)	23	ST-PSx-SG-SE	75
SG2-xx-xxx-00-X (SG2 BASE)	23	SU-LMS-1A	80
SG4 BASE	22	SU-LMS-1B	80
SG4 EXTENDED	50	SWING-18	58
SG4 LONG RANGE BASE	36	TPxx	89
SG4-40-xxx-00-E (SG4 LONG RANGE BASE)	37	Type	11





2025 RELEASE UNDER E.O. 14176

## HEADQUARTERS

### Datalogic Automation Srl

Via Lavino, 265  
40050 Monte San Pietro - Bologna - Italy  
Tel. +39 051/6765611  
Fax +39 051/6759324  
info.automation.it@datalogic.com

## BRANCHES AND SALES OFFICES

## EUROPE BENELUX

### Datalogic Automation Benelux

Newtonweg 3  
4104 BK Culemborg  
The Netherlands  
Tel. +31 345/589489  
Fax +31 345/511419  
info.automation.nl@datalogic.com

## FRANCE

### Datalogic Automation Srl

Succursale en France  
Le Parc Technologique de Lyon  
333 cours du 3ème Millénaire - Le Pôle  
69800 Saint Priest  
Tél. +33 (0)4/72476180  
Fax +33 (0)4/72470721  
info.automation.fr@datalogic.com

## GERMANY

### Datalogic Automation Srl

Niederlassung Central Europe  
Gottlieb-Stoll-Straße 1,  
73271 Holzmaden  
Tel. +49 7023 7453-100  
Fax +49 7023 7453-129  
info.automation.de@datalogic.com

## ITALY

### Datalogic Automation Srl

Via Lavino, 265  
40050 Monte San Pietro - Bologna  
Tel. +39 051/6765611  
Fax +39 051/6759324  
info.automation.it@datalogic.com

### Datalogic Automation Srl

**LASER MARKING**  
Via Le Gorrey, 10  
11020, Donnas - Aosta  
Tel. +39-0125-8128201  
Fax +39-0125-8128401  
info.automation.it@datalogic.com

Via Dell'Industria, 15, 21018  
Sesto Calende - Varese  
Tel. +39-03319180601  
Fax +39-03319180801  
info.automation.it@datalogic.com

## SPAIN

### Datalogic Automation Iberia

Sucursal en España  
C/Samontà, 21 Planta baja, Local 0  
08970 Sant Joan Despí - Barcelona  
Tel. +34 (0)93/4772059  
Fax +34 (0)93/477272  
info.automation.es@datalogic.com

## NORDIC

### Datalogic Automation AB

Höjdrodergatan 21  
21239 Malmö - Sweden  
Tel. +46 (0)40/385000  
Fax +46 (0)40/385001  
info.automation.se@datalogic.com

## UNITED KINGDOM

### Datalogic Automation UK

Datalogic House  
Dunstable Road, Redbourn - Hertfordshire  
AL3 7PR  
Tel. +44 (0) 1582 791750  
Fax +44 (0) 1582 791769  
info.automation.uk@datalogic.com

## TURKEY

### Datalogic ADC Turkey

No:16 Neo Vista Sitesi C1 Blok D.7  
Gokturk/Kemerburgaz  
34077 - Istanbul, Turkey  
info.adc.tr@datalogic.com

## NORTH AMERICA

### Datalogic Automation Inc

511 School House Road  
Telford, PA 18969-1196 - United States  
Tel. +1-800-BAR-CODE or +1-215-723-0981  
Fax +1-215-721-5551  
info.automation.us@datalogic.com

### Datalogic Automation Inc

**MACHINE VISION**  
5775 W Old Shakopee Rd  
STE 160, Bloomington, MN 55437 United States  
Tel. +1-952-996-9500  
Fax +1-952-996-9501  
info.automation.us@datalogic.com

## SOUTH AMERICA

### Datalogic Brazil

Avenida Olivio Roncoletta, 465  
Bairro Vila Hortolandia Jundiã (SP), Brazil  
Tel. +55 11 29232600  
orders.ia.int@datalogic.com

## APAC

## AUSTRALIA-NEW ZEALAND

### Datalogic Automation Pty Ltd

Unit 130, 45 Gilby Road  
Mt Waverley - Victoria, 3149 - Australia  
Tel. +61 (0)3/95589299  
Fax: +61 (0)3/95589233  
info.automation.au@datalogic.com

## CHINA

### Datalogic Automation Asia

Floor 20, Room 2017, Building 2,  
16 West Nan San Huan Road  
Fengtai District, Beijing  
Tel: +86 (0)21-5836 6692  
Fax: +86 (0)21-5836 6695  
info.automation.cn@datalogic.com

Suite 1301, Hua Rong Plaza,  
1289 South Pudong Road, Pudong District  
Shanghai 200120  
Tel: +86 (0)21-5836 6692  
Fax: +86 (0)21-5836 6695  
info.automation.cn@datalogic.com

Room 1104B, 5#Tower, Fantasta MIC Plaza,  
West Nanhai Road, Nanshan District,  
518054 Shenzhen, Guangdong, China  
Tel: +86 (0)755-8629 6779  
Fax: +86 (0)755-8628 1280  
info.automation.cn@datalogic.com

1202, Excellence Build, 128 Yanji Road,  
Shibei District, Qingdao, China  
Tel: +86 532 55787889  
Fax: +86 532 55787890

## JAPAN

### Idec Datalogic Co. Ltd

10-40, Mikuni-Honmachi 1-Chome,  
Yodogawa-ku, Osaka 532 0005  
Tel. +81(6) 6398/3200  
Fax +81 (6) 6398/3202  
www.idljp.com

Rev. 04, 03/2015



9C514200E

Product and Company names and logos referenced may be either trademarks or registered trademarks of their respective companies. We reserve the right to make modifications and improvements.



**DATALOGIC**  
THE VISION IS YOURS

www.datalogic.com